



US007627633B2

(12) **United States Patent**
Rechterman et al.

(10) **Patent No.:** **US 7,627,633 B2**
(45) **Date of Patent:** **Dec. 1, 2009**

(54) **PROXY EMAIL METHOD AND SYSTEM**

6,286,045 B1 9/2001 Griffiths et al.

(75) Inventors: **Barbara J. Rechterman**, Cave Creek, AZ (US); **Joshua T. Coffman**, Mesa, AZ (US); **Robert R. Parsons**, Scottsdale, AZ (US)

(Continued)

FOREIGN PATENT DOCUMENTS

(73) Assignee: **The Go Daddy Group, Inc.**, Scottsdale, AZ (US)

GB 2347053 A 8/2000

(*) Notice: Subject to any disclaimer, the term of this patent is extended or adjusted under 35 U.S.C. 154(b) by 528 days.

(Continued)

OTHER PUBLICATIONS

(21) Appl. No.: **10/526,107**

Zenel, Bruce, "A General Purpose Proxy Filtering Mechanism Applied to the Mobile Environment," Wireless Networks, 1999, pp. 391-409, vol. 5, J.C. Baltzer AG.

(22) PCT Filed: **Aug. 30, 2002**

(86) PCT No.: **PCT/US02/27956**

(Continued)

§ 371 (c)(1),
(2), (4) Date: **Feb. 28, 2005**

Primary Examiner—Frantz B Jean
(74) *Attorney, Agent, or Firm*—Gallagher & Kennedy, P.A.; Thomas D. MacBlain

(87) PCT Pub. No.: **WO2004/029821**

PCT Pub. Date: **Apr. 8, 2004**

(57) **ABSTRACT**

(65) **Prior Publication Data**

US 2006/0015868 A1 Jan. 19, 2006

(51) **Int. Cl.**
G06F 15/16 (2006.01)

(52) **U.S. Cl.** **709/206; 709/207; 379/88.22; 717/174**

(58) **Field of Classification Search** 709/214, 709/225, 226, 205, 206–207, 202, 217, 219, 709/238; 726/6, 22, 12; 718/1; 379/88.22; 717/174, 175

See application file for complete search history.

(56) **References Cited**

U.S. PATENT DOCUMENTS

6,044,205 A 3/2000 Reed et al.
6,230,188 B1* 5/2001 Marcus 709/206

A system and method of proxy (60) domain name registration permits a would-be domain name registrant anonymity. A registrar (24) affords customers (20) the opportunity to use the proxy registration. If the customer seeking registration of a domain name requests, the registrar obtains contact information needed for registration from a proxy entity established for this purpose. The registrar completes the registration of the domain name with the appropriate registry (22) (i.e. ".com, .net" etc.). The contact information published in WHOIS (27) is that of proxy entity. Contractually the customer is afforded control over the domain name. Emails intended for the customer are received by the proxy entity who may filter them if the customer requests. Emails sent by the customer are sent to the proxy entity who in turn send them to the indicated addressee.

14 Claims, 21 Drawing Sheets

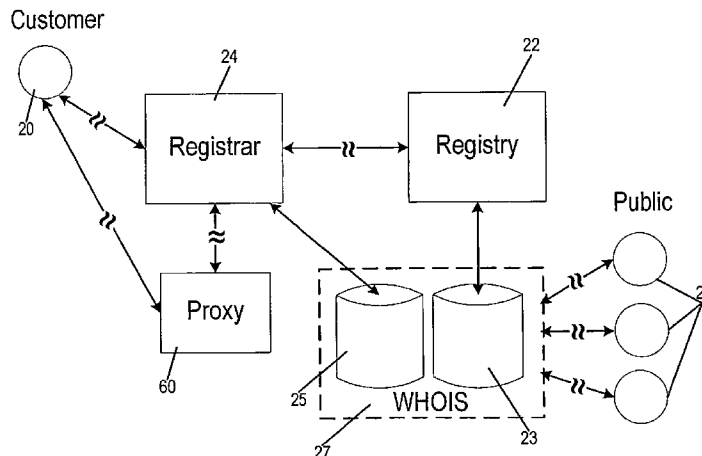

U.S. PATENT DOCUMENTS

6,308,203	B1	10/2001	Itabashi et al.	
6,311,207	B1	10/2001	Mighdoll et al.	
6,314,459	B1	11/2001	Freeman	
6,321,267	B1	11/2001	Donaldson	
6,330,605	B1	12/2001	Christensen et al.	
6,345,294	B1	2/2002	O'Toole et al.	
6,434,600	B2	8/2002	Waite et al.	
6,446,133	B1	9/2002	Tan et al.	
6,477,577	B1	11/2002	Asano	
6,480,508	B1*	11/2002	Mwikalo et al.	370/475
6,519,589	B2	2/2003	Mann et al.	
6,643,687	B1*	11/2003	Dickie et al.	709/206
6,675,208	B1	1/2004	Rai et al.	
6,687,746	B1	2/2004	Shuster et al.	
6,745,248	B1*	6/2004	Gardos et al.	709/245
6,868,498	B1	3/2005	Katsikas	
6,880,007	B1*	4/2005	Gardos et al.	709/225
7,006,993	B1*	2/2006	Cheong et al.	705/38
7,007,093	B2	2/2006	Spicer et al.	
2002/0091827	A1*	7/2002	King et al.	709/226
2002/0178381	A1	11/2002	Lee et al.	
2003/0191969	A1*	10/2003	Katsikas	713/201
2005/0188045	A1	8/2005	Katsakas	
2005/0289084	A1	12/2005	Thayer et al.	

FOREIGN PATENT DOCUMENTS

JP	10275119	A	10/1998
JP	2001167017	A	6/2001
JP	2002063116	A	2/2002
JP	2002091874	A	3/2002
JP	2002297938	A	10/2002

WO WO 99 06929 2/1999

OTHER PUBLICATIONS

Hall, Robert J., "How to Avoid Unwanted Email," Communications of the ACM, Mar. 1998, pp. 88-95, vol. 41, No. 3.

Smith, R.N. et al., "Operating Firewalls Outside the LAN Perimeter," Performance, Computing and Communications Conference, Feb. 1999, pp. 493-498, IEEE International.

Deloria, W.C. et al., "DMS Service Management," Military Communications Conference, Nov. 1995, pp. 967-971, vol. 3, IEEE.

Exchange of "alt.fan.starwars" in Google Groups, "How You Can Tell the Title is a Hoax" (3 pp.).

Website page of register.com (1 p.).

Entry in "http://www.prwatch.org"—"Phillip Morris Uses 'Account Masking'" (1 p.).

WIPO Administrative Panel Decision, Marian Keyes & Old Barn Studios Ltd., case No. D2002-0687 (7 pp.), (Sep. 23, 2002).

Securities and Exchange Commission Form S-1 of Register.com, Inc., Mar. 2, 2000 (2 pp.).

"Anonyme Domains möglich," German language document, Nov. 28, 2001 (1 p.).

Register.com, Inc. 2001 Annual Report including Securities and Exchange Commission Form 10-K (5 pp.).

"Account masking" search results on Google Groups (1 p.).

Web pages of interNONYMOUS.com, "See The Difference," (2 pp.).

Web page of interNONYMOUS.com, "Order Form," (1 p.).

Web pages of interNONYMOUS.com, "Services and Prices," (3 pp.).

Web pages of interNONYMOUS.com, "Frequently Asked Questions," (3 pp.).

Web page of interNONYMOUS.com, "MSNBC: The Selling of WHOIS Data," (4 pp.).

Web page of interNONYMOUS.com (1 pp.).

* cited by examiner

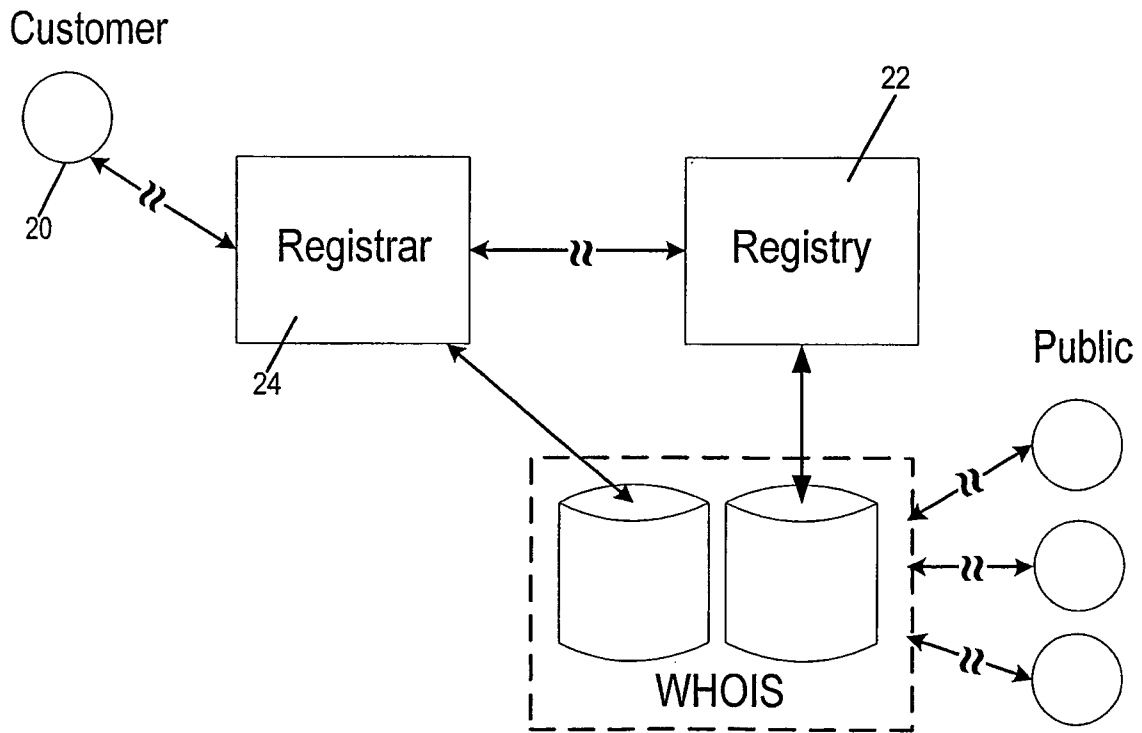

Fig. 1
Prior Art

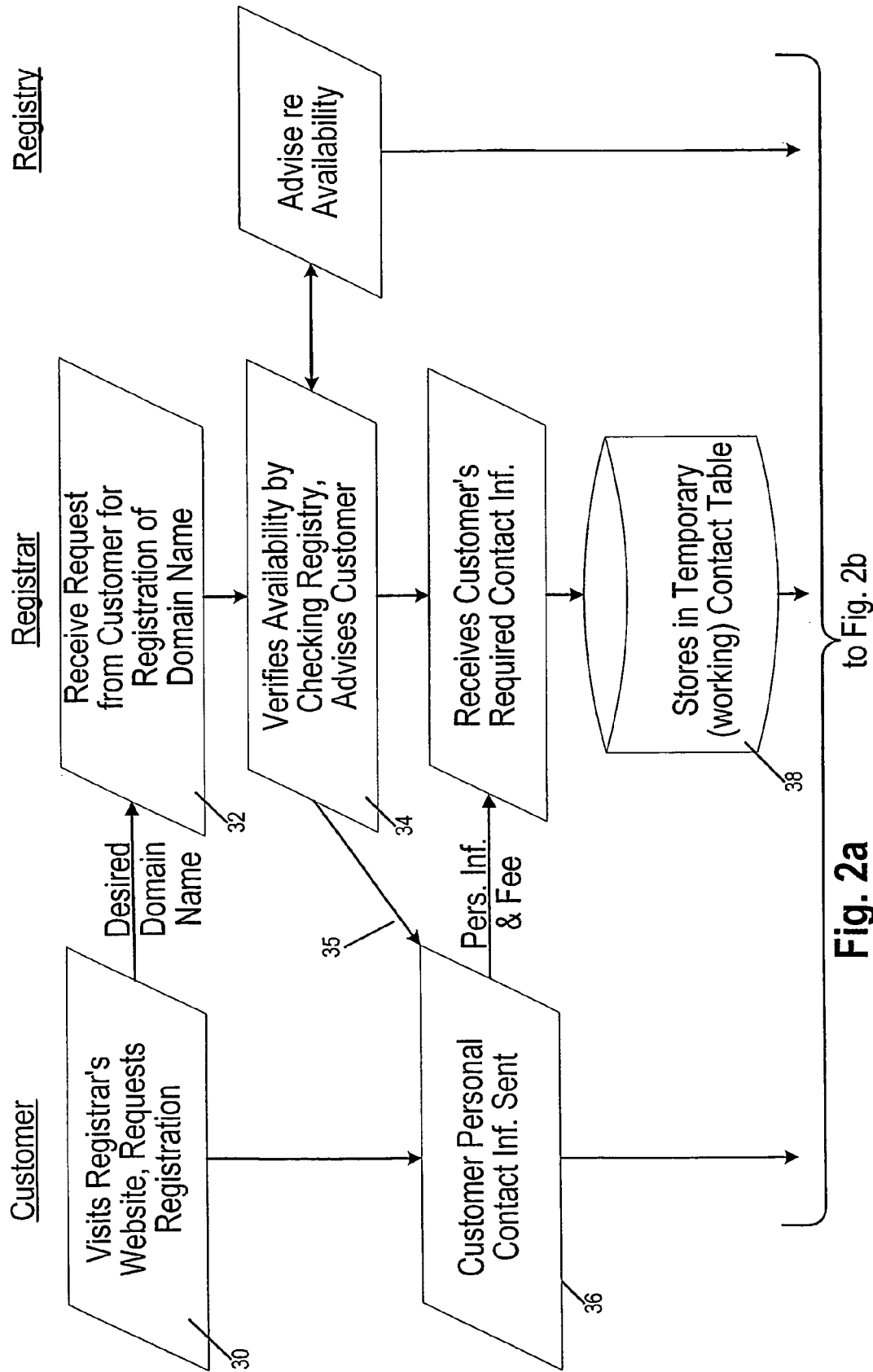

Fig. 2a
Prior Art

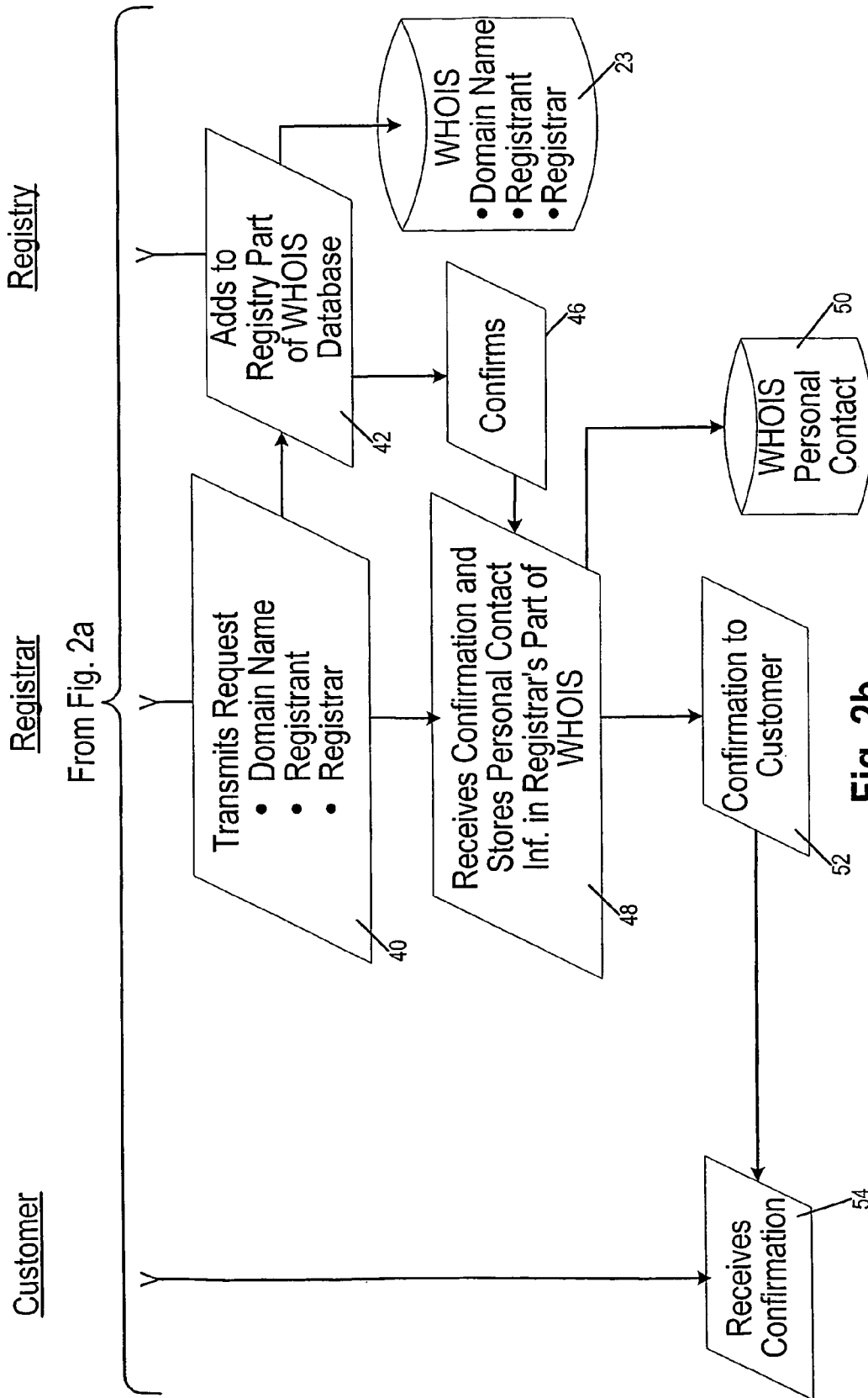

Fig. 2b
Prior Art

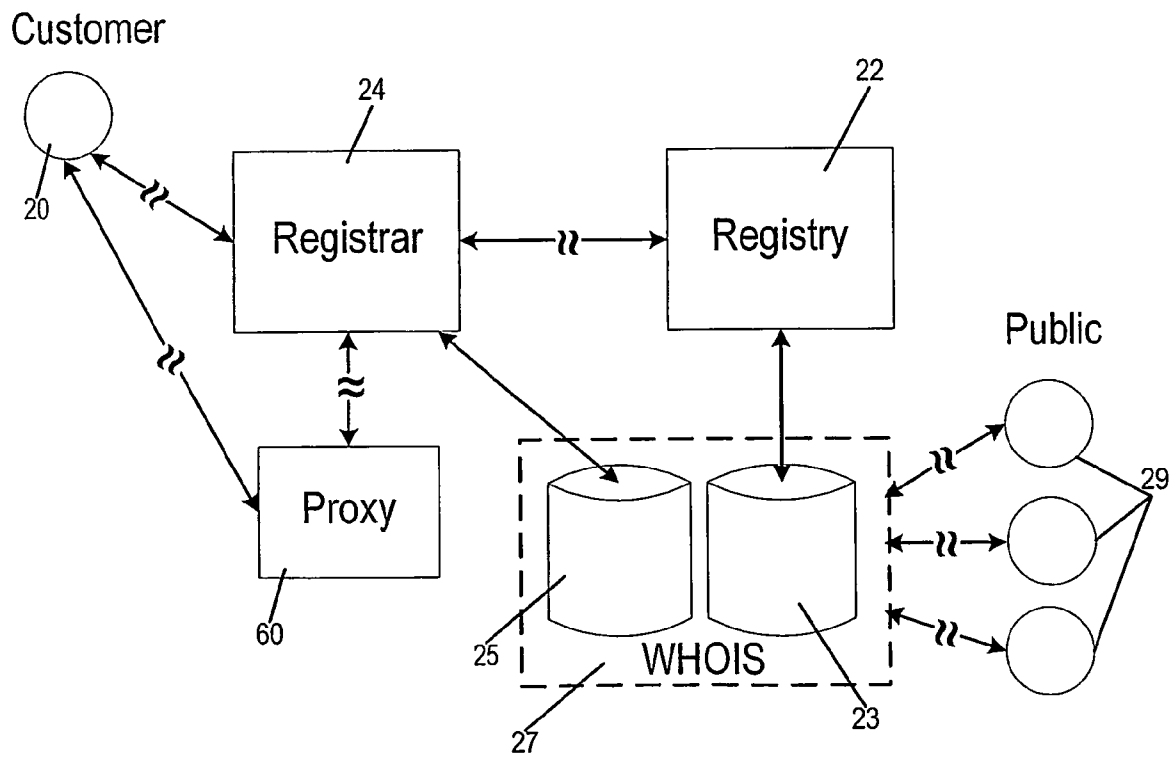

Fig. 3

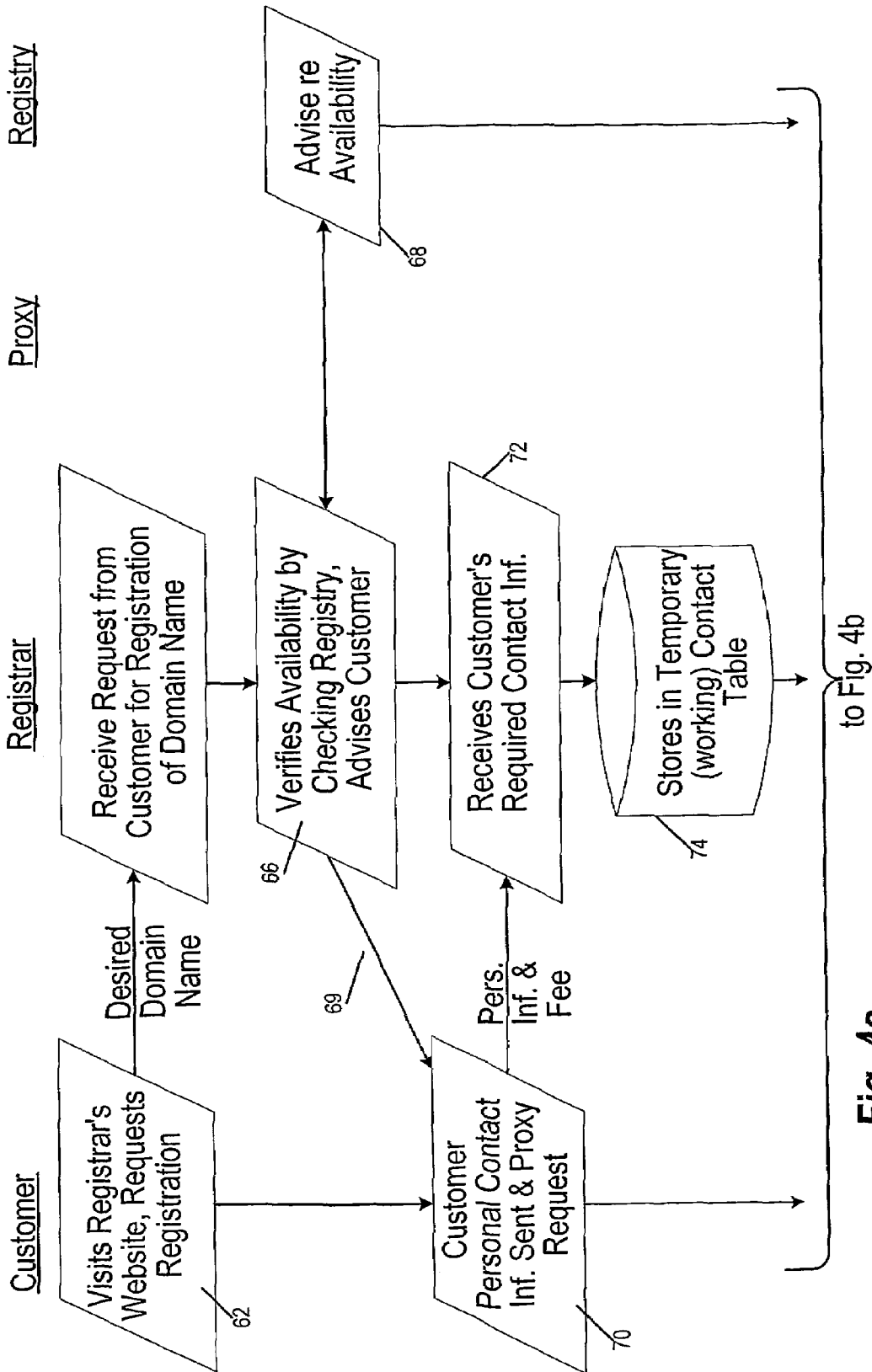

Fig. 4a

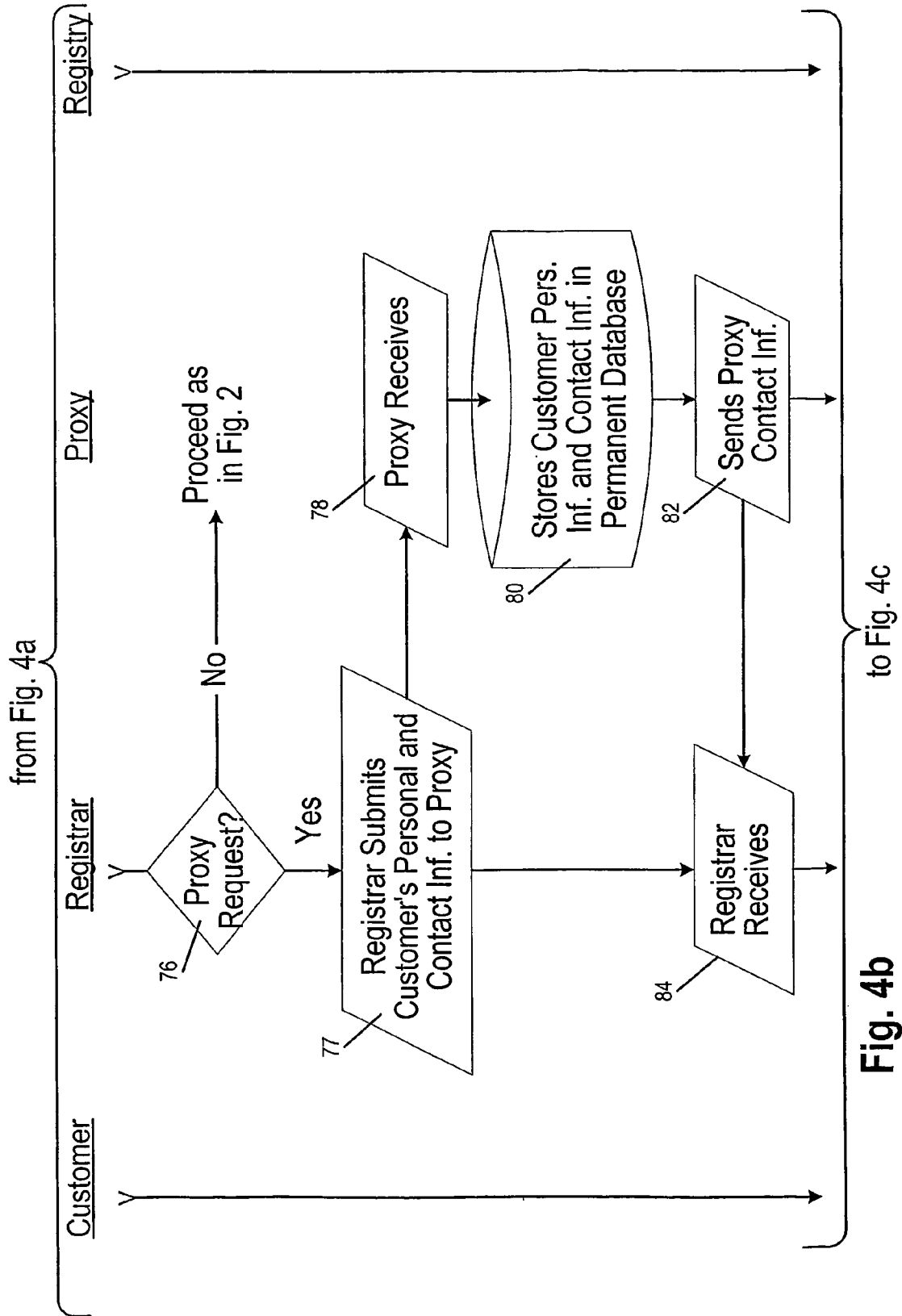

Fig. 4b

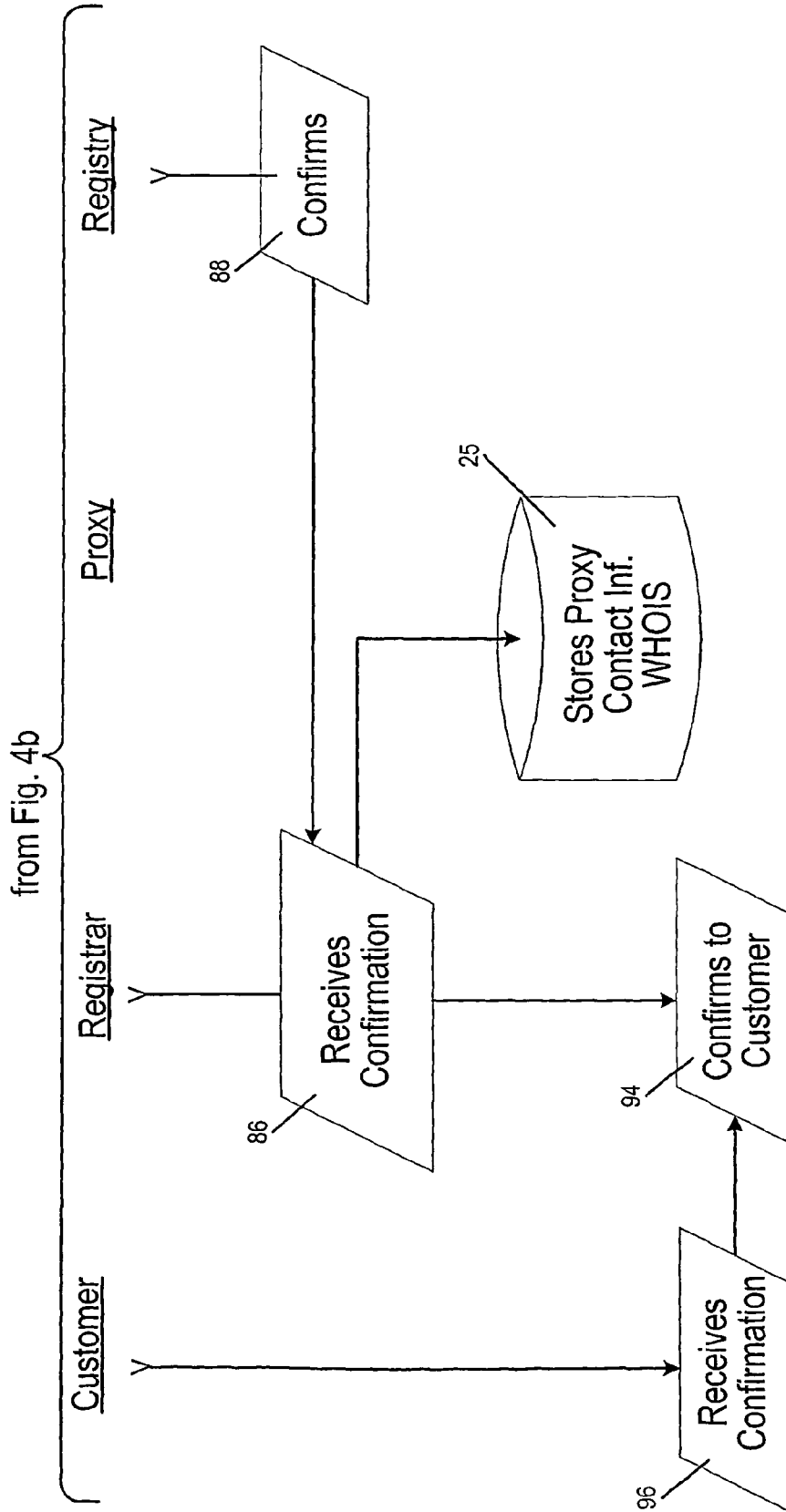

Fig. 4C

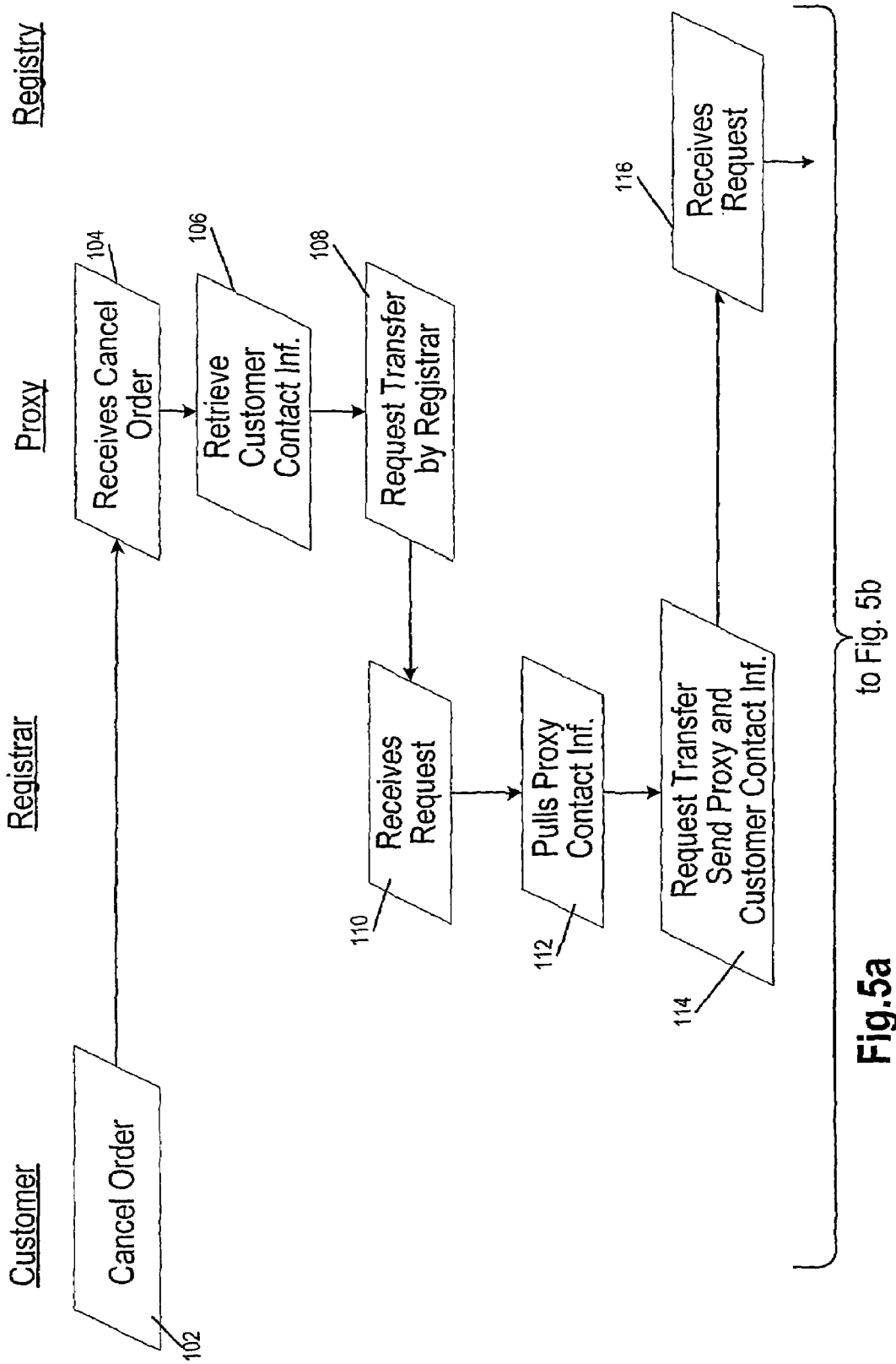

Fig.5a

to Fig. 5b

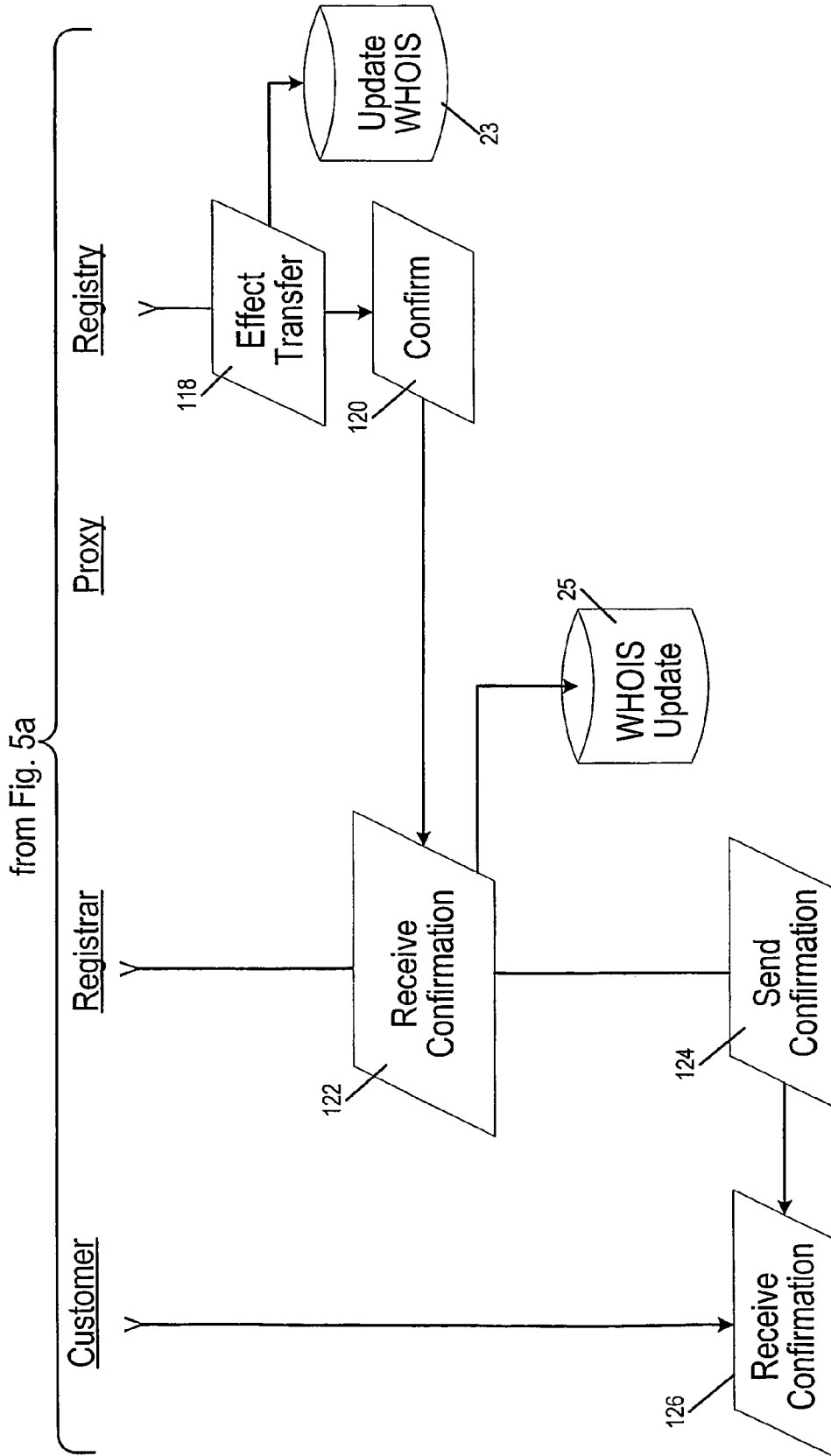

Fig. 5b

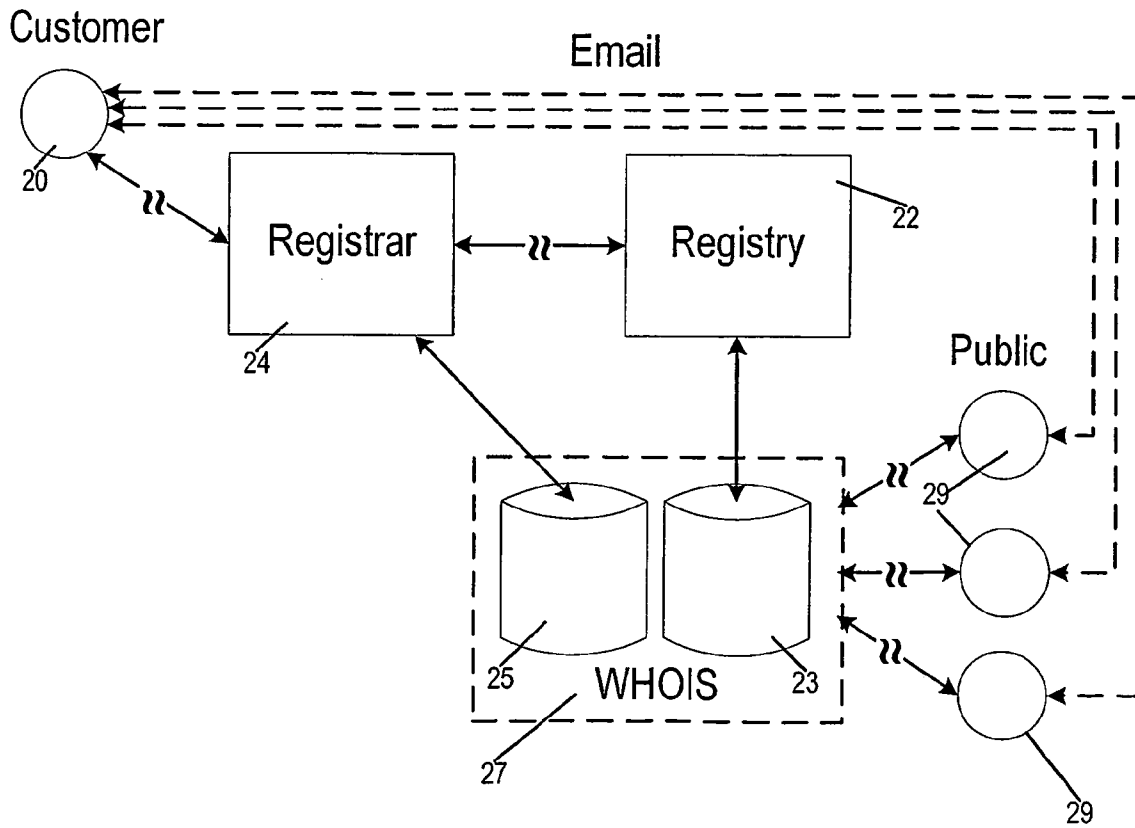

Fig. 6
Prior Art

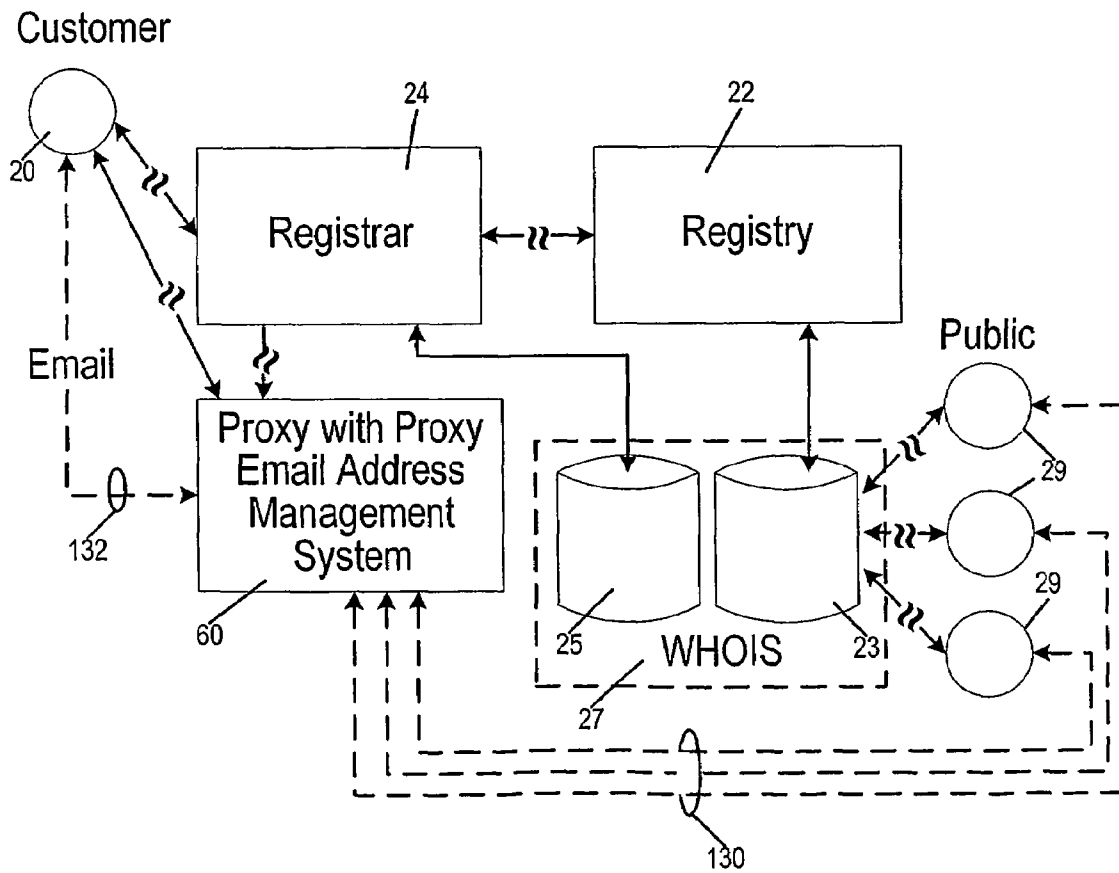

Fig. 7

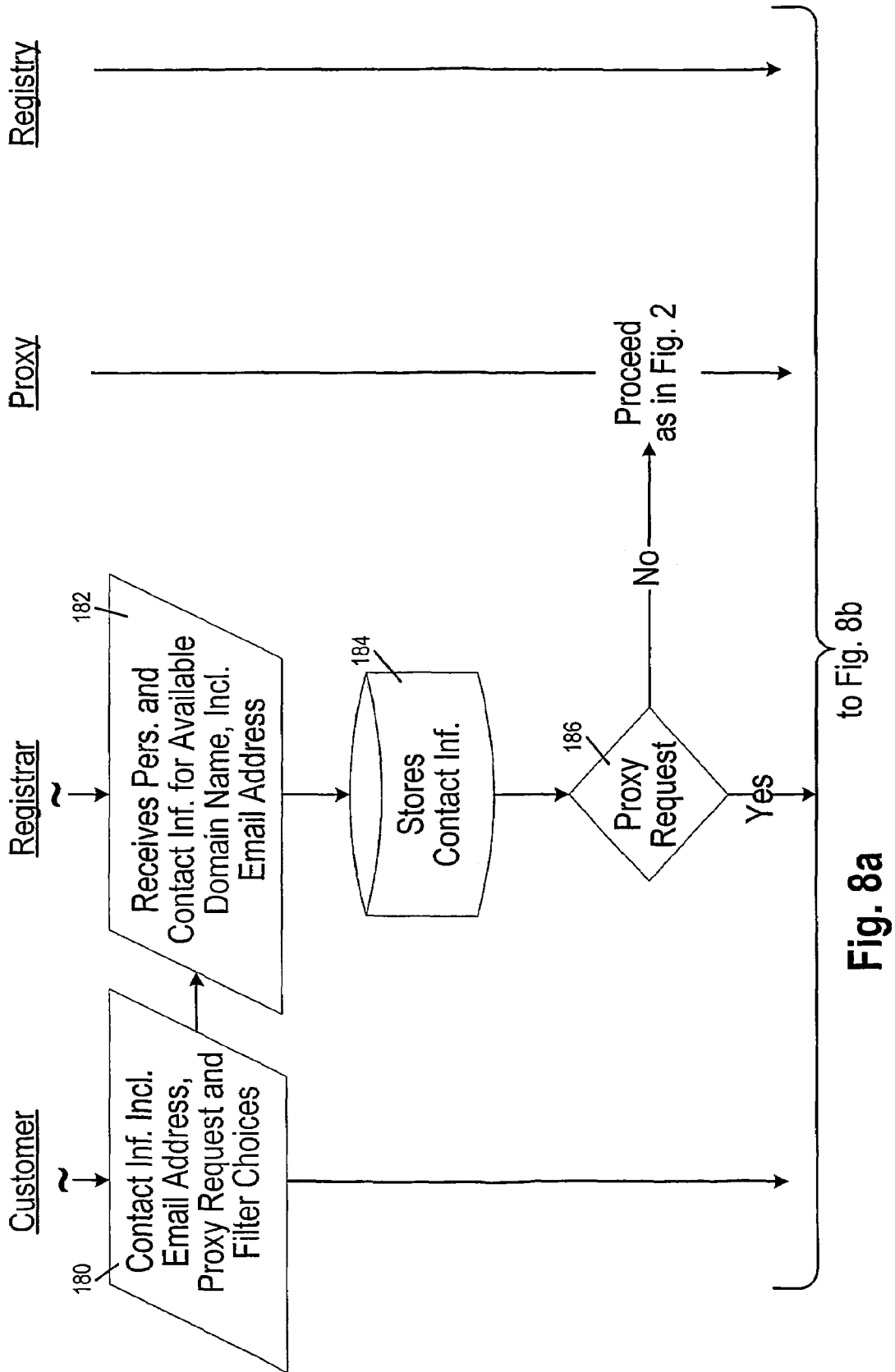

Fig. 8a

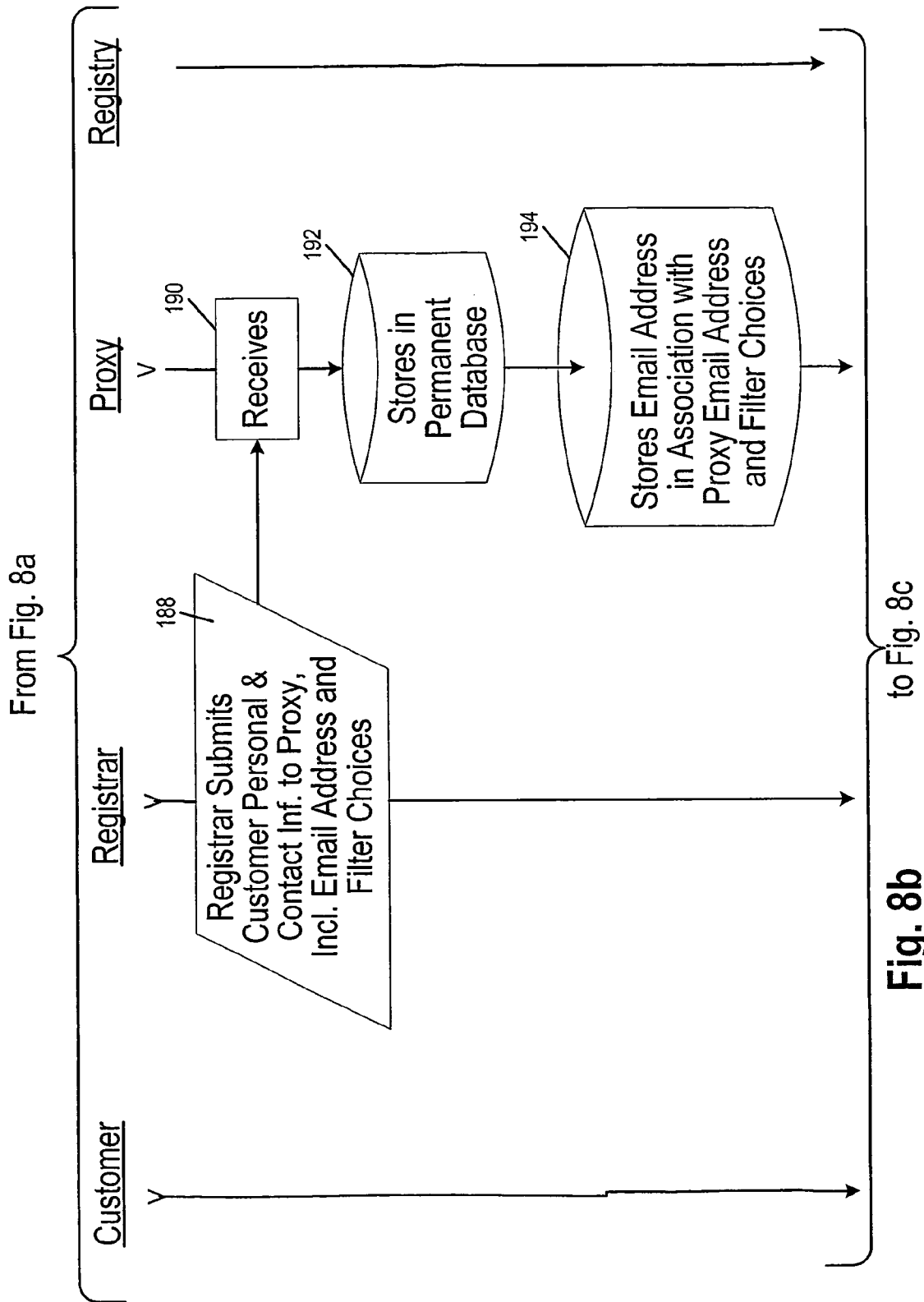

Fig. 8b

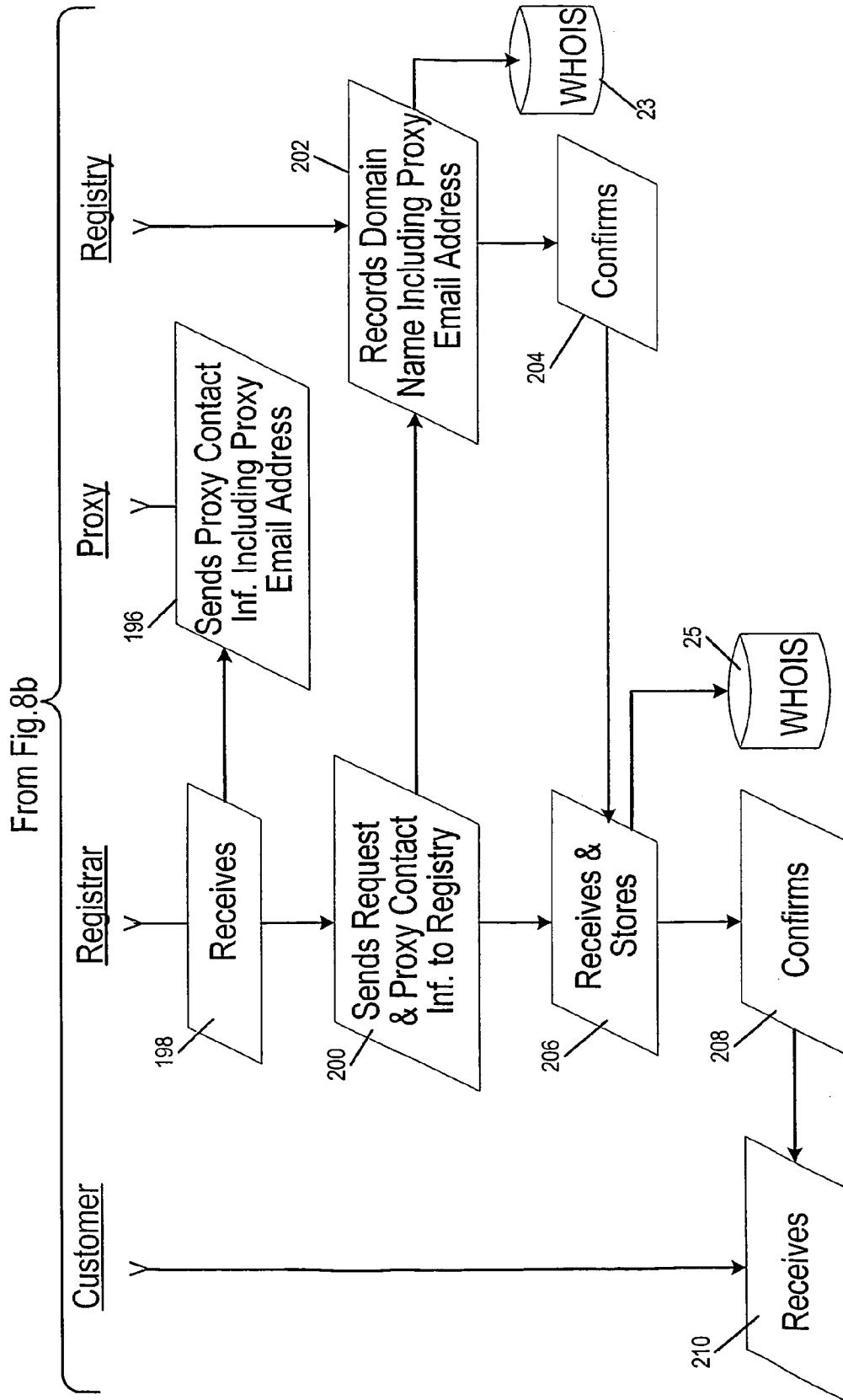

Fig. 8c

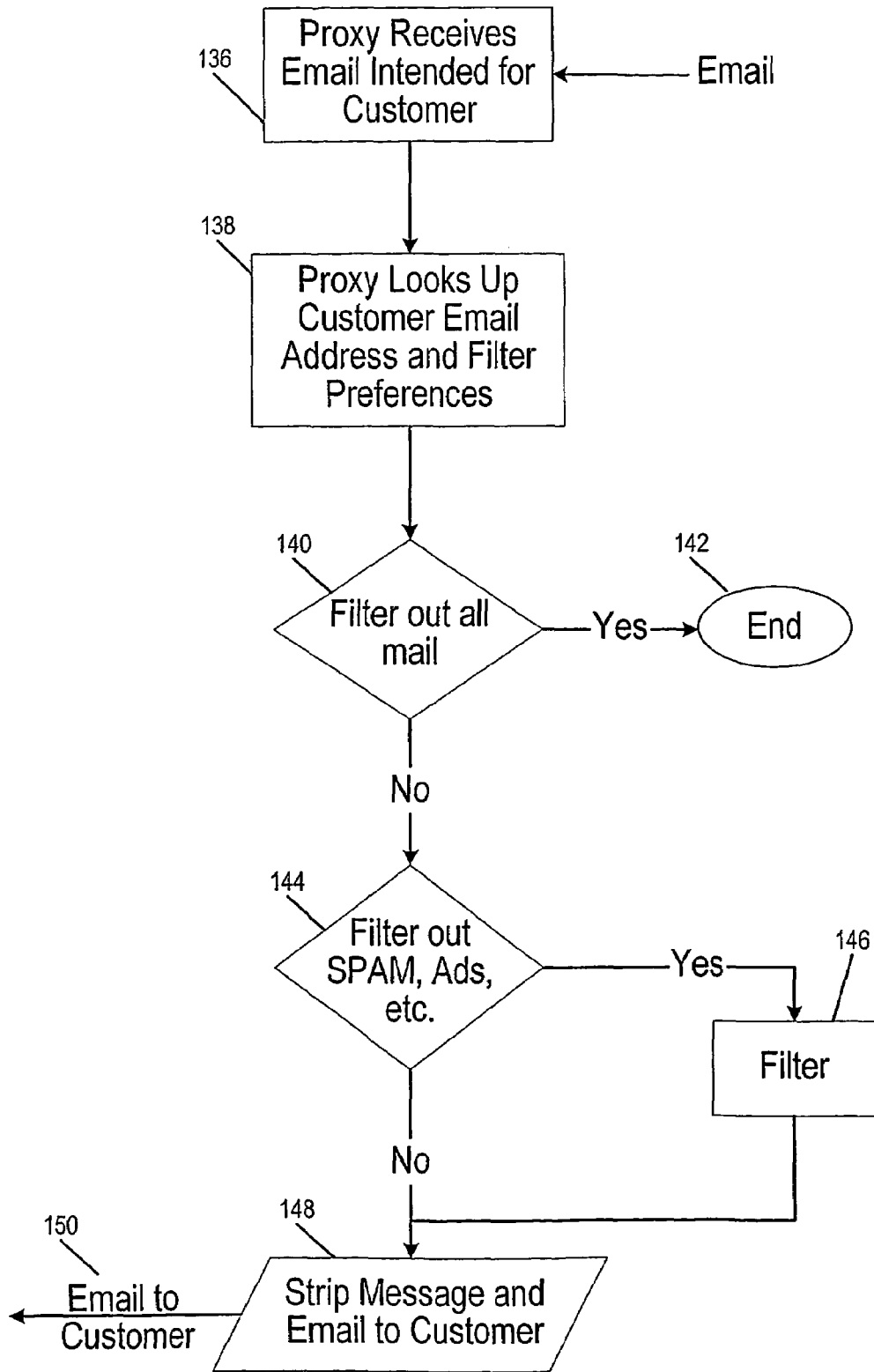

Fig. 9

▶ WHOIS Search Results

Registrant:

Gallagher & Kennedy (GKNET-DOM)
2600 N. Central Ave
Phoenix, AZ 85004
US

Domain Name: GKNET.COM

Administrative Contact:

Ulan, Gail (GU212) gmu@GKNET.COM
Gallagher & Kennedy
2600 N. Central Ave
Phoenix, AZ 85004
602-530-8000 (FAX) 602-530-8000

Technical Contact:

Center, Network Control (NCC7) ncc@WESTPUB.COM
West Publishing Corporation
620 Opperman Drive
St. Paul, MN 55164-0779
612/687-8188 (FAX) 612/687-5710

Record expires on 30-Mar-2011.

Record created on 29-Mar-1996.

Database last updated on 30-Aug-2002 14:54:01 EDT.

Domain servers in listed order:

NS1.WESTGROUP.NET	163.231.229.1
NS2.WESTGROUP.NET	163.231.245.1

Fig. 10

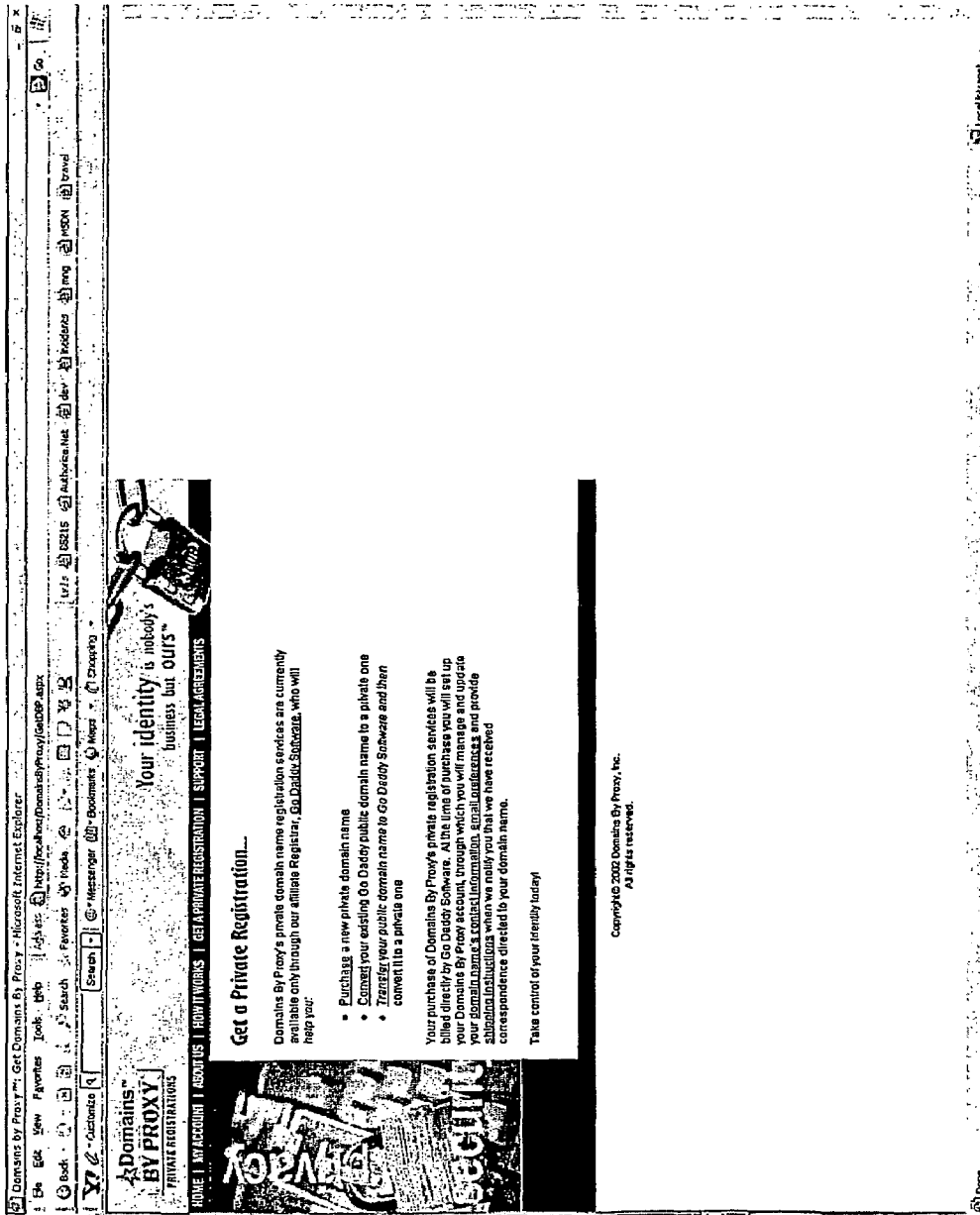

Fig. 11

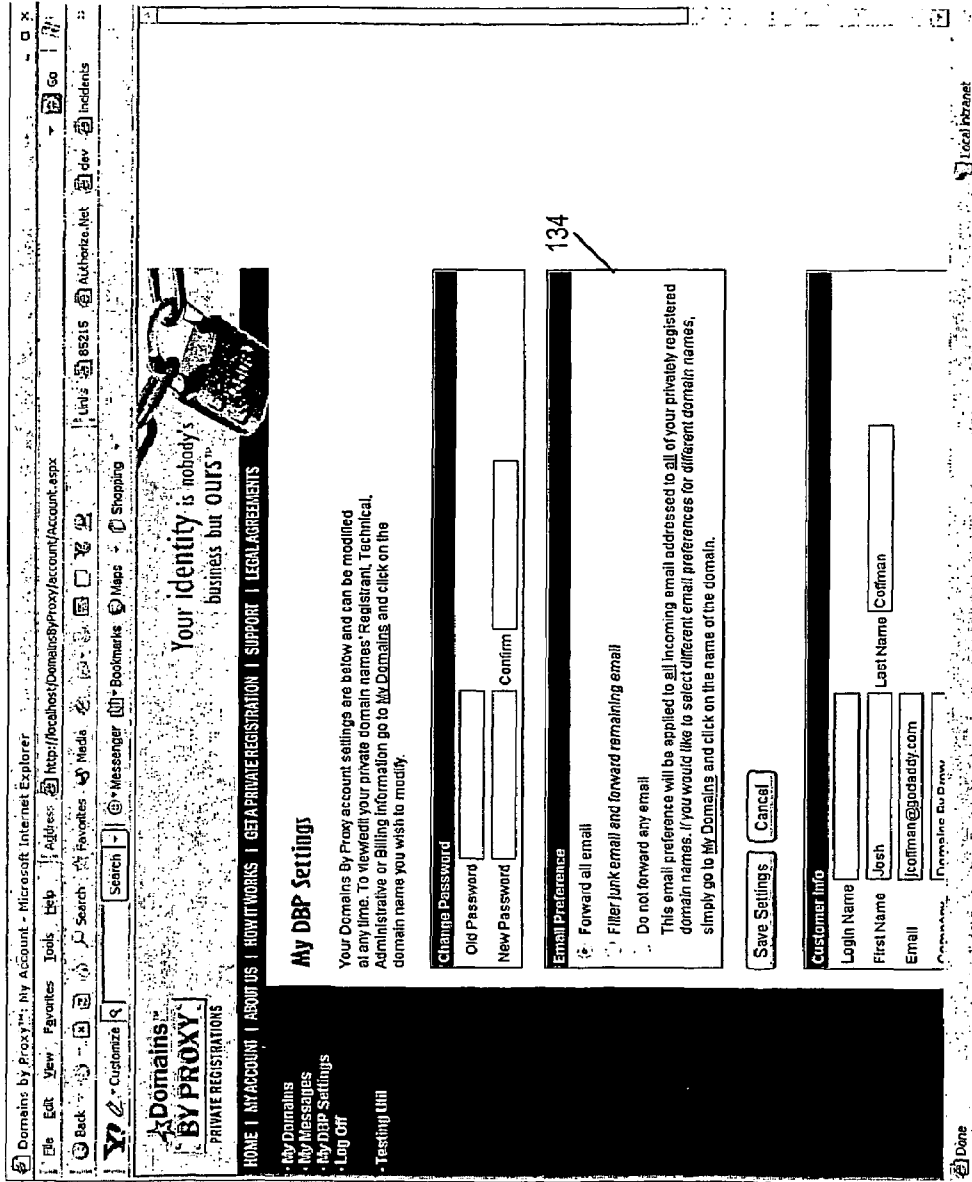

Fig. 12

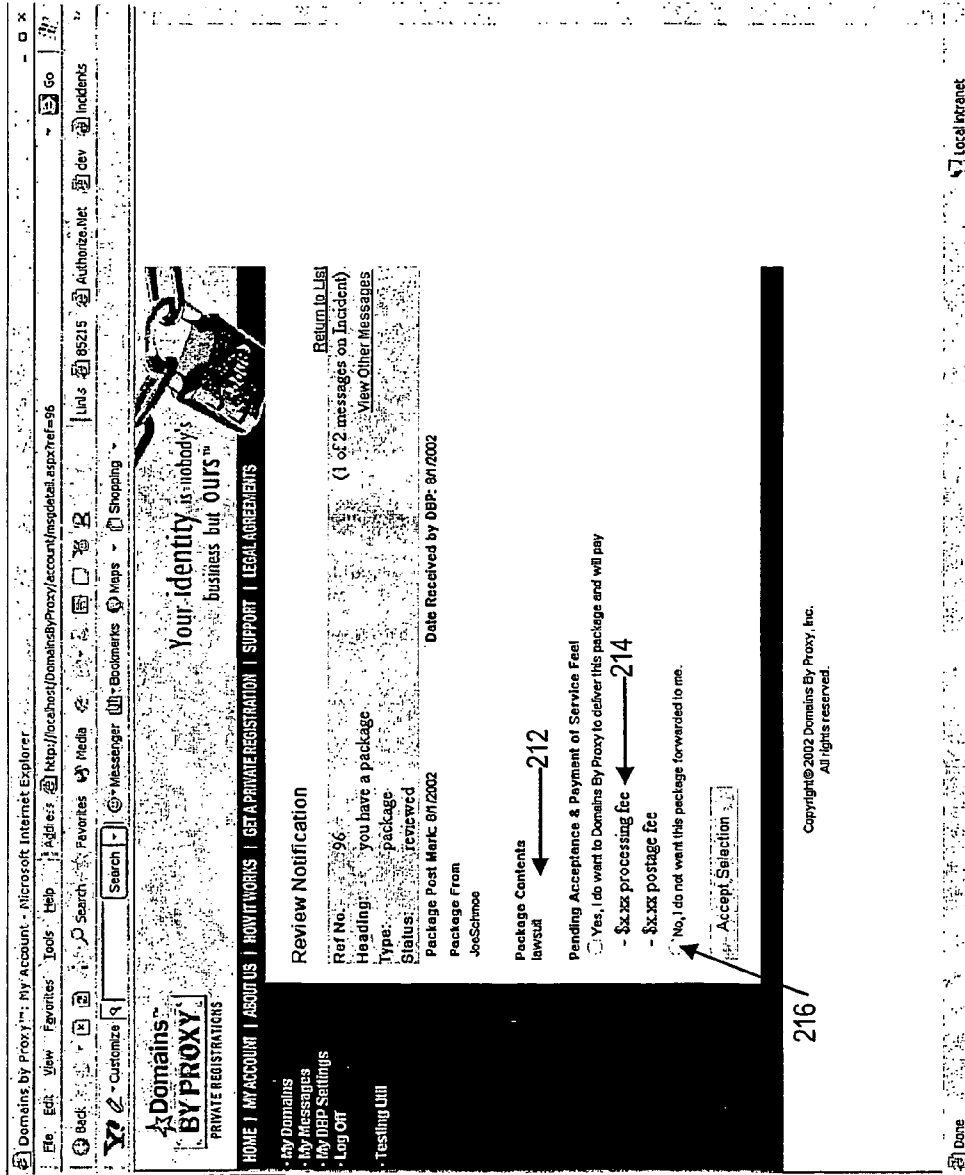

Fig. 13

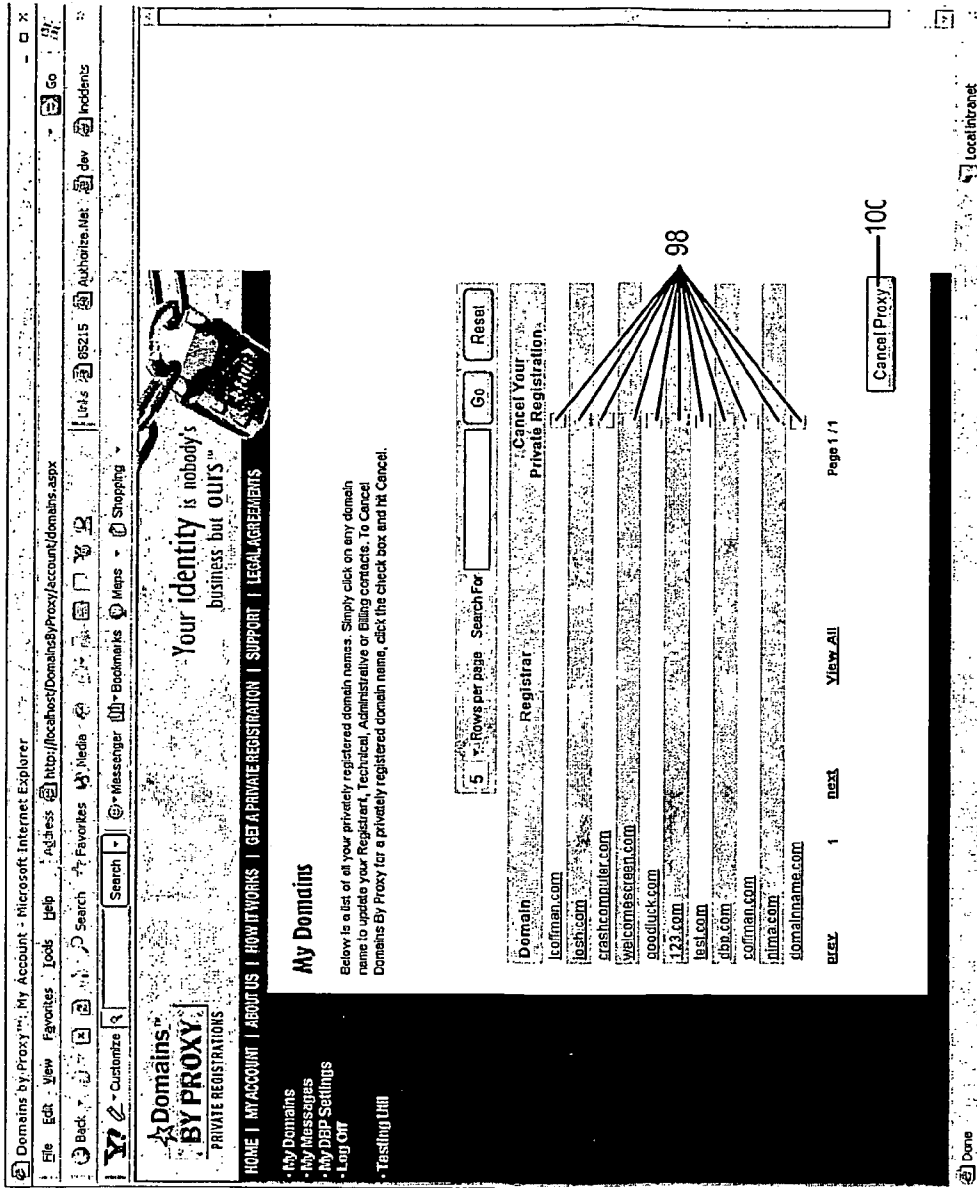

Fig. 14

Domains by Proxy™: My Account - Microsoft Internet Explorer
 http://localhost/DomainProxy/account/messages.aspx
 Home | My Account | About Us | How It Works | Get A Private Registration | Support | Legal Agreements

Domains BY PROXY
 PRIVATE REGISTRATIONS

HOME | MY ACCOUNT | ABOUT US | HOW IT WORKS | GET A PRIVATE REGISTRATION | SUPPORT | LEGAL AGREEMENTS

• My Domains
 • My Messages
 • My DBP Settings
 • Log Off
 • Testing Unit

My Messages

The following messages have been sent regarding your privately registered domain name(s).
 Click on the links below to sort by column. Click on the subject to view the message.

Date	Status	Subject	Domain(s)
8/7/2002	reviewed	your account is up for renewal	coifman.com
8/7/2002	reviewed	your account is up for renewal	coifman.com
8/7/2002	reviewed	your account is up for renewal	coifman.com
8/7/2002	new message	your account is up for renewal	coifman.com
8/7/2002	new message	your account is up for renewal	coifman.com
8/7/2002	new message	your account is up for renewal	coifman.com
8/7/2002	reviewed	your account is up for renewal	coifman.com
8/7/2002	new message	your account is up for renewal	coifman.com
8/7/2002	reviewed	your account is up for renewal	coifman.com
8/7/2002	new message	your account is up for renewal	coifman.com

REV 1 2 3 next View All Page 1 / 3

Copyright © 2002 Domains By Proxy, Inc.
 All rights reserved.

Fig. 15

PROXY EMAIL METHOD AND SYSTEM

CROSS REFERENCE TO RELATED APPLICATIONS

This application is a U.S. National Stage Continuation of International application No. PCT/US02/27956 filed Aug. 30, 2002 in the U.S. Receiving Office, having the same title and naming the same inventors as this application, priority from which is hereby claimed. This application is a division of U.S. patent application Ser. No. 10/624,883 filed Jul. 21, 2003, which is now U.S. Pat. No. 7,130,878, and which is a U.S. National Stage continuation of International application No. PCT/US02/27742 filed Aug. 30, 2002. Both the application Ser. No. 10/624,883 and the U.S. Pat. No. 7,130,878 are entitled, "Systems and Methods for Domain Name Registration By Proxy," and both name as inventors Robert R. Parsons, Joshua T. Coffman and Barbara J. Rechterman. The preceding International application is entitled "Method and System for Domain Name Registration and Email by Proxy" and names Robert R. Parsons, Joshua T. Coffman and Barbara J. Rechterman as inventors. This application is also related to U.S. patent application Ser. No. 11/498,500 filed Aug. 2, 2006, entitled "Systems and Methods for Domain Name Registration by Proxy," a division of the aforementioned U.S. patent application Ser. No. 10/624,883, and also naming as inventors Robert R. Parsons, Joshua T. Coffman and Barbara J. Rechterman.

FIELD OF THE INVENTION

The present invention relates to a method and system for proxy domain name registration and, more particularly, to a method and system for privately registering domain names over the Internet.

BACKGROUND OF THE INVENTION

The Internet comprises a vast number of computers and computer networks that are interconnected through communication links. The interconnected computers exchange information using various services, such as electronic mail, Gopher, and the World Wide Web ("WWW"). The WWW service allows a server computer system (i.e., Web server or Web site) to send graphical Web pages of information to a remote client computer system. The remote client computer system can then display the Web pages. Each resource (e.g., computer or Web page) of the WWW is uniquely identifiable by a Uniform Resource Locator ("URL"). To view a specific Web page, a client computer system specifies the URL for the Web page in a request (e.g., a HyperText Transfer Protocol ("HTTP") request). These follow the familiar format `http://www.xxx.com` uniquely identifying the particular resource. The request is forwarded to the Web server that supports that Web page to the client computer system. When the client computer system receives that Web page, it typically displays the Web page using a browser. A browser is a special-purpose application program that effects the requesting of Web pages and the displaying of Web pages.

Currently, Web pages are typically defined using HyperText Markup Language ("HTML"). HTML provides a standard set of tags that define how a Web page is to be displayed. When a user indicates to the browser to display a Web page, the browser sends a request to the server computer system to transfer to the client computer system an HTML document that defines the Web page. When the requested HTML document is received by the client computer system, the browser

displays the Web page as defined by the HTML document. The HTML document contains various tags that control the displaying of text, graphics, controls, and other features. The HTML document may contain URLs or other Web pages available on that server computer system or other server computer systems.

Generally a Web page's address or URL is made up of the name of the server along with the path to the file or the server. Rather than using a Web hosting service's server name as their URL, most companies and many individuals and other entities prefer a "domain name" of their own choosing. In other words, the Ford Motor Company probably would prefer `http://www.ford.com` as its URL rather than, say, `http://servername.com/-ford`, where "servername" is the name of a Web hosting service whose server The Ford Motor Company uses. For this purpose then a "domain name," e.g. "ford" can be registered, if available, and the hosting service will use that URL for its customer's Web address.

The process of registering one's own domain name proceeds as follows: Referring to FIG. 1 shown there are the various entities that participate in the registration of a domain name. The communications like those shown here and in other Figures of the drawings are typically communications via the Internet, but could be direct LAN, or WAN connections, telephone land line or cell phone links, communications by RF or optic fibers among others. An individual, company, small business or other entity **20** (hereinafter "customer") desires to obtain his/her own domain name using one or more of the Internet Corporation for Assigned Names & Numbers ("ICANN") approved top level domain ("TLD") name extensions (e.g., .com, .net, .org, .us, .biz, etc.). All domains are organized through a shared, central domain name registration system. There is one domain name registration system, or registry **22** for each of the ICANN-approved TLDs. Each registry **22** is operated and maintained by an ICANN-approved company **20**. The entities **20**, **24** and **22** in FIG. 1 include, of course, computer installations equipped typically for Internet communication. FIG. 1 assumes that the customer **20** has a server or servers. It may, however, contract with another, a host who provides servers as is conventional. This does not change the relationship of the entities involved here and so is not separately shown.

The process for registering a domain name with a particular registry requires a customer to use an ICANN accredited registrar **24**. For example, John Doe wishes to register the following domain name: "johndoe.com". Initially, John Doe must verify whether the desired domain name is or is not available, by contacting the ICANN-accredited registrar **24**. Utilizing a database search engine run by the registrar **24**, at **30** in FIG. 2, JohnDoe can ascertain whether "johndoe.com" has already been registered by another customer by requesting the domain name from the registrar at **32**. The registrar determines if the domain name is available at **34**. If the desired domain name has not been registered, the registrar so advises the customer, at **35**. The customer can proceed with the registration, utilizing the services of any ICANN approved registrar.

Regardless of the registrar used to process the registration, the customer must (together with payment of the registrar's applicable fees), provide certain personal information at **36** in order to complete the registration. That information includes the customer's address and personal contact information including email addresses, phone numbers and mailing addresses of administrative and technical contacts. The registrar stores the customer contact information and domain name in a temporary, working contact table at **38**. Thereafter, with the registration request, the registrar transmits, at **40**,

certain information to the registry regarding both the registrar and the customer, who will, upon completion of the registration process, be identified as the “registrant” of the domain that is now officially registered with the registry. The registry adds, at 42, the domain name, the registrant’s name and identification of the registrar to the part 23 of the WHOIS database 27 kept by the registry. The registry confirms registration at 46. The registration process is concluded by the registrar confirming the registration to the customer at 52 and 54.

Upon completion of the registration process at 41, certain identifying information is made publicly available in a database managed by each registrar. This is the registrar’s portion 25 of the WHOIS database 27 shown on FIG. 1. For each registered domain name, the registrar’s WHOIS database identifies the name of registrar, the registrar’s “WHOIS” homepage link, the date the domain name was registered and the domain name’s expiration date. The WHOIS database also makes public the registrant’s personally identifiable information, specifically the registrant’s name and postal address, phone number and email address, the name of administrative and technical contacts, and their respective postal address, voice and fax telephone numbers and email addresses and the name of the servers upon which the registered domain name is located.

The registrar’s WHOIS database is accessible by anyone who has Internet access, anywhere and anytime. Although the use to which WHOIS data can be put is limited by ICANN, the registrant’s personally identifiable information is required to be readily available to the public, including those who would seek to engage in data mining, SPAMMING, or other potentially undesirable activities. A typical WHOIS record from a registrar is shown in FIG. 10.

For certain domain name registrants, it would be desirable if the personal contact information required to be displayed on the WHOIS database were not available. For example, a celebrity who wishes to participate in activities on the WWW might not want her identity and other information known so as to avoid harassment, stalking, hacking, data mining or simply “prying eyes.” It would be desirable if such persons could anonymously participate in Web-related activities, even having a home page, without their true identity being known, but without violating the rules set down by ICANN. Typically, domain name owners receive email at an email address that contains their domain name ordinarily. For example, xxx@yyy.com is an email address where yyy is the registrant’s domain name. Because of the availability of the registrant’s email address on the WHOIS record available from the registrar, a member of the public can address email to the registrant. In addition to shielding its domain name registrant from unwanted contact including harassment, stalking, prying, and the like, it could be desirable to keep the domain name registrant’s email address confidential. It could further be desirable in many instances for that registrant to have access to the email intended for it without having to publish its email address for all to see. In addition it could be desirable to the anonymous Web participant to respond anonymously to email or to originate email anonymously.

Filtering of email messages to preclude junk email, SPAM, unauthorized bulk email, unauthorized commercial email, pornography, viruses, worms, Trojan horses, and other harmful submissions would often be desirable, as well.

SUMMARY OF THE INVENTION

In accordance with this invention, a system and method for the registration of domain names employs a proxy entity

(“proxy”) to maintain the confidentiality of a domain name owner. A would-be domain name registrant can choose to have its desired domain name registered in the name of the proxy. The publicly available registrant information lists just the proxy’s personal contact information.

Email intended for the customer is diverted to the proxy registrant whose email address appears on the publicly available registration information WHOIS. The proxy can, if the customer desires, filter out unwanted email, block all email, or forward all email to the customer.

Contractually, the customer enjoys the full rights of ownership of the domain name. The customer can: cancel the proxy’s services anytime in which case ownership of the domain name will revert back to the private registrant; sell, transfer or assign the domain name to anyone else, in which event the purchaser, transferee or assignee will become the official “registrant” of record with the applicable registry; control and/or manage each domain name, including designating the IP address to which each domain name points; cancel each domain name’s registration; renew each domain name upon its expiration; and have a right of first refusal should proxy’s ownership of the domain name become subject to creditor’s claims. The system permits the customer to cancel the proxy registration at any time by two clicks on a Web page. Upon that command, the registrar who has registered the domain name in the name of the proxy transfers the domain name to the customer, using the customer’s actual contact information.

Typically the communications among the involved participants are among computer installations via the Internet. But, without departing from the invention, they could be by those other communication modes mentioned above.

In accordance with one embodiment of the invention, a would-be domain name customer contacts the registrar who then checks with the registry to see if the domain name is available. If it is, the registrar so advises the customer, requests the customer’s personal contact information and asks if the customer chooses to register by proxy. Of course, this is done by interactive screens that are a part of the registrar’s Web site.

If the customer declines to register by proxy, then the registrar completes registration in the ordinary fashion. In that case, it will be the customer’s personal contact information and email address that appears in the WHOIS records as usual.

On the other hand, if the customer decides to register by proxy, the registrar temporarily records the customer’s personal contact information in a temporary, working table. The registrar contacts the proxy entity and obtains from the proxy entity the personal contact information of the proxy entity. The registrar then registers the chosen domain name in the name of the proxy and gives the proxy’s personal contact information. The proxy, then, is the actual registrant and owns the domain name. As stated, however, all of the rights of ownership are contractually made available to the customer. The registrar gives to the proxy the customer’s personal contact information, and the proxy stores that in a permanent record along with the domain name. The registrar stores the proxy’s name, the domain name, and the proxy’s personal contact information and email address in its permanent database record, which is the registrar’s portion of the WHOIS database.

Once the registrar completes the registration, the proxy will notify the individual, via email, that an account with the proxy has been opened and request that the individual “click”

5

on a link to activate the account. The individual will also be given a password so that the individual can access his/her proxy account.

If the customer chooses, email intended for the customer will go to the proxy if the sender has determined the email address from the WHOIS record or from another location such as a Web site or print media listing the proxy email address. During the registration process, the registrar has the customer indicate whether it wishes to receive all email addressed to the proxy email address, no email addressed to that address, or email from which objectionable mail has been filtered.

If filtration is chosen by the customer during registration, then the proxy uses familiar filtration principles based on key words in the message, known SPAM originators in the "from" field, and the number of addressees in either the "from" or the "cc:" field to determine if there is objectionable content, if the email has come from a known source of SPAM, or if the email is being emailed in bulk.

Of course the described operations are effected through programming at the registrar and the proxy entity. When the proxy's email server receives email it determines whether it is real email for the proxy or email intended for a customer. Email addressed to the proxy entity that is to be forwarded has its message stripped and copied into an email from the proxy along with the sender's email identity and the alert that "this message was sent to you at the proxy email address."

The above and further objects and advantages will be better understood with reference to the following detailed description of at least one preferred embodiment taken in consideration with the accompanying drawings.

DESCRIPTION OF THE DRAWINGS

FIG. 1 is a block diagram illustrating the relationship between the participants in a prior art domain name registration process;

FIG. 2 is a functional block diagram in flowchart form illustrating the method of domain name registration typically employed in a prior art registration process;

FIG. 3 is a block diagram like FIG. 1 showing the relationship of participants in a domain name registration process according to this invention;

FIG. 4 is a functional block diagram like FIG. 2 in flowchart form showing the process of proxy domain name registration in accordance with this invention;

FIG. 5 is a functional block diagram in flowchart form showing the steps in cancellation of proxy registration in accordance with this invention;

FIG. 6 is a block diagram showing the relationship of participants in a typical email process;

FIG. 7 is a block diagram like FIG. 6 showing the participants in a proxy email process according to this invention;

FIG. 8 is a functional block diagram in flowchart form illustrating a portion of the proxy registration process by which proxy email is affected.

FIG. 9 is a functional block diagram in flowchart form illustrating the proxy email process;

FIG. 10 is an exemplary WHOIS record available from a registrar;

FIG. 11 is a screen shot illustrating an initial screen by which a customer initiates registration by proxy;

FIG. 12 is a screen shot and illustrates a screen by which a customer can set his choices for email and input his contact's identification;

6

FIG. 13 is a screen shot of a screen by which a customer can accept mail delivery of mail to the proxy address appearing on the WHOIS record;

FIG. 14 is a screen shot showing a screen by which the customer can cancel proxy registration; and

FIG. 15 is a screen shot showing a screen by which a customer can access messages from the proxy.

DETAILED DESCRIPTION

Turning to FIG. 3, the participants in a domain name registration by proxy include the customer 20, the registrar 24, the registry 22, and the proxy entity 60. Each of the registrar 24 and registry 22 has a permanent record portion 23, 25 of the WHOIS database 27. The registry's portion 23 lists domain name, registrant, and registrar information. The registrar's portion 25 lists the information shown in FIG. 10, a representative WHOIS record from a registrar. The customer, registrar and proxy computer installations are typically in communication via the Internet. The registrar and registry are in communication, again typically by Internet. The public indicated at 29 has available to it via the Internet the WHOIS records in the databases maintained by the registry and the registrar.

As illustrated in FIG. 4, proxy registration proceeds as follows. Just as in the prior art FIG. 2a procedure, the customer visits registrar's Web site and requests registration at 62. The customer may be referred from a proxy's screen like that illustrated in FIG. 11. The registrar computer installation receives the request including the desired domain name at 64. It verifies availability at 66 by checking with the registry at 68 and advises the customer 69. As indicated at 70, customer personal contact information, and in this case, a proxy request is supplied to the registrar. The registrar receives it at 72. The registrar stores the customer personal contact information in computer memory in a temporary, working contact table at 74. At 76 the registrar's computer program enters a decision block. If no proxy request has been made the program continues as in FIG. 2. If, as here, proxy registration has been requested, then the registrar's program departs from the prior art FIG. 2 procedure and submits, at 77, the customer's personal contact information to the proxy at 78. At 80 the proxy stores the customer's personal information in its permanent database. The proxy then sends its personal contact information to the registrar at 82. Upon receipt of the proxy contact information at 84, the registrar sends a request for registration of the domain name and the proxy personal contact information to the registry at 86. At 88, the registry receives the request and records the domain name along with the proxy registrant identification and the registrar information in its WHOIS portion 23. Then at 90 the registry confirms the registration.

Upon receiving the confirmation from the registry at 92, the registrar stores the proxy contact information in its permanent table that forms its portion of the WHOIS database 25, at 94 the registrar confirms the registration to the customer, who receives that confirmation at 96.

By a screen shown in FIG. 14, the proxy entity affords the customer the opportunity to cancel proxy registration. The customer checks the relevant domain name by clicking on one or more of the boxes 98 provided and then by clicking on the cancel proxy button 100. As shown in FIG. 5a, at 102, by clicking on the cancel proxy button the customer sends the cancel order to the proxy at 104. The proxy retrieves the relevant customer contact information at 106. At 108 the proxy requests transfer of the registration by the registrar, which receives that request at 110. At 112, the registrar pulls

the proxy contact information. The registrar then sends the request for transfer along with both the proxy contact information and the customer contact information at **114** to the registry at **116**. The registry effects transfer as shown at **118**, FIG. **5b**. The registry updates its portion **23** of the WHOIS database and at **120** sends a confirmation to the registrar which is received at **122**. The registrar updates its portion **25** of the WHOIS database and then sends confirmation at **124** to the customer, who receives it at **126**.

FIG. **7** shows the relationship of the participants in a proxy email address management system. As previously, the proxy **60** is the proxy domain name registrant. Email senders **29** who learn of the proxy registrant's email address from WHOIS **27**, or from another source, send their email to the proxy email address as indicated at **130**. The proxy **60** forwards such email as the customer has indicated he or she is interested in receiving. This is indicated at **132**.

As shown in the screen shot of FIG. **12**, the customer **29** was given a number of filtration choices at **134**. The customer can elect to have all email forwarded by the proxy **60**, to filter called "junk email" or not to have mail sent to the proxy email address forwarded.

Returning to FIG. **7** in one embodiment, the customer **20** who desires to send email of his or her own addresses the mail to the proxy who then forwards the mail under its own proxy email address. In this embodiment, the customer's email address is not revealed. Alternatively, the proxy only forwards email to the customer. The customer then, if he or she so desires, responds to those emails of interest under its own email address.

FIG. **8** shows the process by which proxy email is established. After it has been determined that the domain name is available as previously described, the customer **20** is prompted for his or her contact information including email address. The customer is also prompted to indicate proxy domain name registration is desired and whether proxy email is desired. If so, the customer's filter choices are to be indicated as indicated at the location **134** on the screen of FIG. **12**. The customer responds at **180**. The registrar receives the contact information including the email address at **182**. It stores these at **184**. At the decision block **186**, it is determined whether a proxy request has been made. If not, the program proceeds as in FIG. **2**. If yes is the answer, the registrar submits customer personal information to the proxy including the email address and filter choices at **188** in FIG. **8b**. The proxy receives the information at **190** and stores it in its permanent database at **192**. At **194** the proxy also stores the email address in association with the proxy email address and filter choices. At proxy **60** of FIG. **7**, for each customer that requests to be registered for proxy email, the email address management system creates a virtual email address according to naming conventions and associates it with that customer's account. At **196** in FIG. **8c** the proxy sends proxy information including the virtual email address to the registrar, which the registrar receives at **198**. The registrar sends the request for domain name registration with the identification of the proxy as the registrant and the registrar information to the registry at **200**. The registry records this information in its portion **23** of WHOIS at **202**. The registry confirms registration at **204**. The registrar receives that confirmation at **206**. At **208** the registrar stores the proxy contact information in its permanent table along with the email address of the proxy and this appears in the WHOIS record **25** administered by the registrar. The registrar then confirms the registration to the customer who receives it at **208**. The customer receives the confirmation at **210**. The customer is now set up to receive email filtered as desired.

The proxy email address management system of the proxy uses the following standards. For the domain name "DomainA.com" the virtual email address dbp.DomainA.com@DomainsByProxy.com is assigned. Thus, the virtual email address is unique to each domain and conflict with a real email address on DomainsByProxy.com, the domain name of the proxy, is improbable.

At the proxy installation an email server is set up to accept emails for the proxy's email address domain. The processing of email by the proxy is shown in FIG. **9**. At **136**, the proxy computer installation receives email from a sender such as one of the individuals **29** in FIG. **7**. At **138**, the proxy sender determines it's an email intended for a customer and looks up the customer email addresses and filter preferences. The email server is configured to send all of the incoming proxy email messages to a common "catch-all" account. Email messages for the email server are stored according to RFC821 (SMTP) requirements. The email address management system periodically checks each account for new email messages via the known POP protocol. This polling model was chosen to separate the email address management system from the email server. Thereby, the email server does not need to have intrinsic knowledge of the management system. The management system is therefore capable of using any email server that supports the POP protocol.

When new email is found, the system iterates through each email found on the email server. For each message, it checks the "To:" addresses and the "Cc:" addresses for virtual email addresses being served by the proxy. If it finds one, it retrieves the real email address for that customer and that customer's email forwarding preference. At **140** it is determined whether the customer has chosen to filter out all email. If that is the case, the program is ended at **132**. If the answer is no, then it is determined whether the customer has sought to filter out junk email, e.g., SPAM, bulk advertisements, etc. If the answer at the decision block **144** is yes, then the proxy uses known programs to determine, based on key words in the message, whether the message is likely to be SPAM, pornography, or other objectionable content. The number of recipients is checked in the "To:" or "Cc:" fields to determine if this is likely bulk solicitations or mailings and these are filtered out. Email from known purveyors of SPAM, bulk mailings and ads can be filtered out. Once filtration is done, the remaining emails are, at **148**, stripped of their message, copied into an email from the proxy to the customer. It is sent to the customer along with the sender's email address and a message that the email was received by the proxy. The email is then forwarded to the customer at **150**. Once every email address for that message has been checked for proxy users, it is deleted from the host email server.

As shown in FIG. **15**, in addition to email, the customer can receive messages directly from the proxy **60**. These are typically messages bearing on the status of the account and also messages that can indicate the receipt of surface mail. Remembering that the contact information in WHOIS includes the proxy's address, persons desirous of sending surface mail will from time to time address that surface mail to the mailing address in the contact information. FIG. **13** is a screen shot illustrating the proxy's communication of, in this case, the receipt of a complaint instituting a suit against the customer. This is shown at the field **212**. At **214** the customer is given the opportunity to say that he or she does wish to receive this mail, or at **216** the customer is given an opportunity to decline receiving the mail.

The foregoing descriptions of at least one preferred embodiment are exemplary and not intended to limit the claimed invention. Obvious modifications that do not depart

from the spirit and scope of the invention as claimed in the following claims will be apparent to those skilled in the art.

We claim:

1. A proxy email computer installation including:
 - (a) a database in computer memory associating a customer's identification, a customer's actual email address and a customer's proxy email address;
 - (b) an email server having an ability to receive a first email message at the customer's proxy email address;
 - (c) computer executable code on a computer usable storage medium or media providing:
 - (i) first programming to retrieve a customer's actual email address from the database upon receipt of the first email message to the customer's proxy email address;
 - (ii) second programming to forward a second email message to the customer's actual email address, wherein the second email message is formed from the first email message; and
 - (d) a connection to a communication link forwarding the second email message to the customer's actual email addresses.
2. The proxy email computer installation according to claim 1, wherein the email server is set up to receive all incoming proxy emails to a common catch-all account, and the email computer installation further comprises an email address management system that periodically checks for new emails for any customer.
3. The proxy email computer installation according to claim 2, wherein the first programming to retrieve a customer's actual email address includes programming to check email addresses of all addressed and copied parties for a proxy email address being served by the proxy email server whenever a new email is found by the email address management system.
4. The proxy email computer installation according to claim 3, wherein the second programming comprises programming to copy the content of the first email message into the second email message, the second email message comprising an email message from the proxy computer installation to the customer at the customer's actual email address.
5. The proxy email computer installation according to claim 4, further comprising programming in computer executable code on a computer usable storage medium or media to effect deletion of an email once addresses of all addressed and copied parties have been checked for proxy email addresses of customers and any content has been copied to an email to the actual email addresses of any customers whose proxy email addresses have been found.
6. A proxy email computer installation including:
 - (a) a database in computer memory storing customer information in association with a proxy email address, wherein the customer information includes a customer's actual email address;
 - (b) an email server to receive an email intended for a customer at the proxy email address;
 - (c) computer executable code on a computer-usable storage medium or media providing:
 - (i) first programming to detect the email received at the email server intended for the customer;
 - (ii) second programming for retrieving the customer's actual email address from the database upon receipt of the email;

- (iii) third programming to forward the email to the customer's actual email address; and
- (d) a connection to a communication link for forwarding the email to the customer's actual email address.
7. The proxy email computer installation according to claim 6, further comprising:
 - (e) a filtering software in computer-executable code on a computer-usable storage medium or media for preventing an objectionable email being forwarded to the customer.
8. The proxy email computer installation according to claim 7, further comprising, in said database, an indication of customer's choice or choices for an email filtering.
9. The proxy email computer installation according to claim 8, wherein the customer's choice or choices includes one of:
 - (i) no filtering;
 - (ii) blocking all emails addressed to the proxy email address associated with the customer's information; and
 - (iii) blocking objectionable emails addressed to the proxy email address associated with the customer's information.
10. The proxy email computer installation according to claim 9, wherein the blocked objectionable email is selected from the group consisting of SPAM, bulk email, advertising, pornography and code to interfere with a computer's workings.
11. A computer program for proxy email address management comprising in computer-executable code on a computer usable storage medium or media:
 - (a) first programming establishing a database for storing customer information in association with a proxy email address, wherein the customer information includes a customer's actual email address;
 - (b) second programming to identify a first email intended for a customer addressed to the proxy email address;
 - (c) third programming to retrieve the customer's actual email address;
 - (d) fourth programming to copy content of the first email to a second email; and
 - (e) fifth programming operative to send the second email to the customer's actual email address.
12. The computer program in a computer-executable code on a computer usable storage medium or media according to claim 11, further comprising sixth programming to identify a third email from the customer, and seventh programming for copying content of the third to a fourth email for the customer's intended recipient.
13. The computer program in a computer-executable code on a computer usable storage medium or media according to claim 11, further comprising sixth programming for filtering out objectionable emails.
14. The computer program in a computer-executable code on a computer usable storage medium or media according to claim 13, further comprising seventh programming for receiving a customer's choice or choices of filtering and for storing the choice or choices in the database, and eighth programming to recognize the customer's choice or choices and filter or not filter emails to the customer based on the customer's choice or choices.