



US 20090240709A1

(19) **United States**

(12) **Patent Application Publication**  
**Adelman et al.**

(10) **Pub. No.: US 2009/0240709 A1**

(43) **Pub. Date: Sep. 24, 2009**

(54) **INTERACTIVE DNS FOR  
NON-CONTROLLING PARTY**

**Publication Classification**

(75) Inventors: **Warren Adelman**, Scottsdale, AZ (US); **Justin Jilg**, Mesa, AZ (US); **Nathan Curran**, Phoenix, AZ (US)

(51) **Int. Cl.**  
**G06F 17/30** (2006.01)  
(52) **U.S. Cl.** ..... **707/100; 707/E17.005**

(57) **ABSTRACT**

Correspondence Address:  
**GO DADDY GROUP, INC.**  
**14455 NORTH HAYDEN ROAD, SUITE 219**  
**SCOTTSDALE, AZ 85260 (US)**

A Hosting Entity or another entity may provide a framework for collecting DNS Business Information from a Non-Controlling Party of a domain name and entering it into DNS. The framework may include a website, webpage, web service, web resource, software, API, or another technological solution suitable for collecting DNS Business Information from Non-Controlling Party. The website, webpage, web service, or the web resource may be located at URL associated with a Controlling Party's domain name, e.g. an active or a parked page for the domain name. DNS Business Information will be typically available for viewing to everyone along with the traditional DNS information.

(73) Assignee: **The Go Daddy Group, Inc.**, Scottsdale, AZ (US)

(21) Appl. No.: **12/051,718**

(22) Filed: **Mar. 19, 2008**

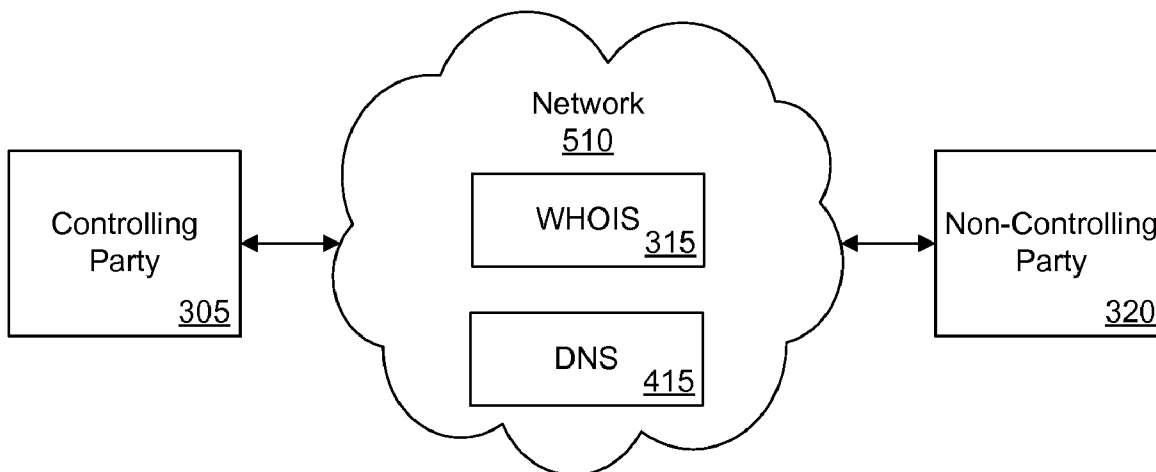

Registrant:  
GoDaddy.com, Inc.

14455 N Hayden Rd #226  
Scottsdale, Arizona 85260  
United States

Registered through: GoDaddy.com, Inc. (<http://www.godaddy.com>)  
Domain Name: GODADDY.COM  
Created on: 02-Mar-99  
Expires on: 02-Mar-16  
Last Updated on: 24-Jan-07

Administrative Contact:  
GoDaddy.com, Inc., GoDaddy.com, Inc. [dns@jomax.net](mailto:dns@jomax.net)  
GoDaddy.com, Inc.  
14455 N Hayden Rd #226  
Scottsdale, Arizona 85260  
United States  
4805058800 Fax -- 4805058844

Technical Contact:  
GoDaddy.com, Inc., GoDaddy.com, Inc. [dns@jomax.net](mailto:dns@jomax.net)  
GoDaddy.com, Inc.  
14455 N Hayden Rd #226  
Scottsdale, Arizona 85260  
United States  
4805058800 Fax -- 4805058844

Domain servers in listed order:  
CNS1.SECURESERVER.NET  
CNS2.SECURESERVER.NET  
CNS3.SECURESERVER.NET

Registry Status: clientDeleteProhibited  
Registry Status: clientRenewProhibited  
Registry Status: clientTransferProhibited  
Registry Status: clientUpdateProhibited

FIG. 1 (prior art)

```
$TTL 86400

@      IN      SOA      ns1.sample-dns-server.com. info.example.com. (
                          2008021501 ; YYYYMMDDnn, where 'nn' is the revision
                          10800      ; Refresh
                          3600       ; Retry
                          604800     ; Expire
                          3600)      ; Minimum

example.com.      IN NS      ns1.sample-dns-server.com.
example.com.      IN NS      ns2.sample-dns-server.com.
ns1.sample-dns-server.com.  IN A      68.178.12.176
ns2.sample-dns-server.com.  IN A      68.178.12.121
webmail.example.com.      IN A      68.178.12.176
mssql.example.com.      IN A      68.178.12.176
sitebuilder.example.com.  IN A      68.178.12.176
mail.example.com.      IN A      68.178.12.176
example.com.      IN A      68.178.12.176
ftp.example.com.      IN CNAME  example.com.
www.example.com.      IN CNAME  example.com.
example.com.      IN MX      10 mail.example.com.
```

FIG. 2 (prior art)

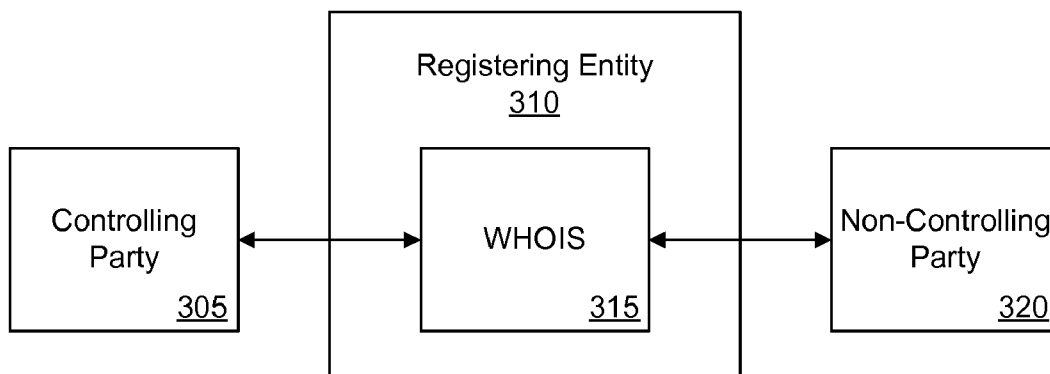

FIG. 3

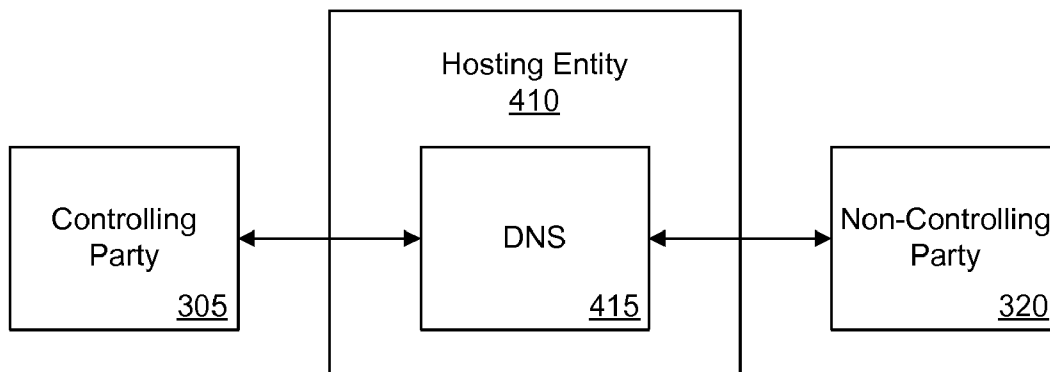

FIG. 4

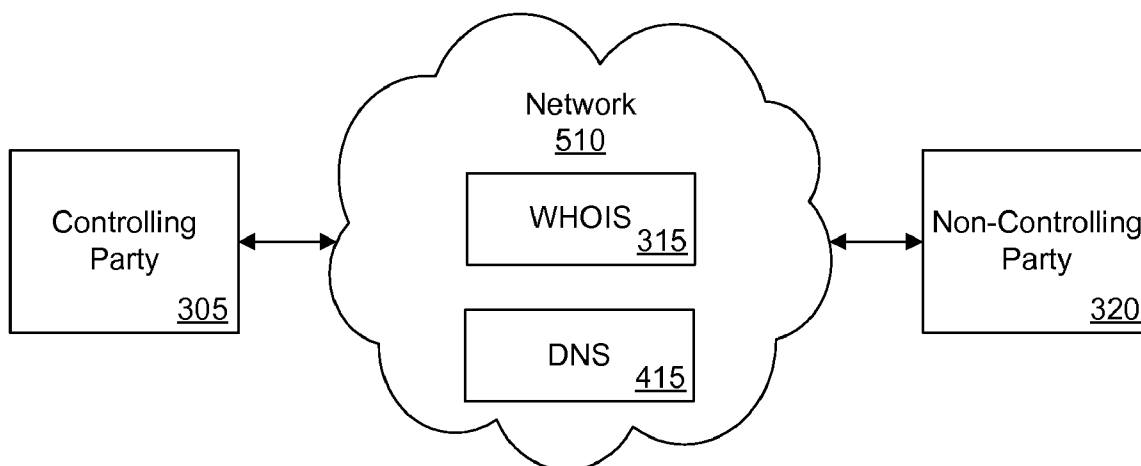

FIG. 5

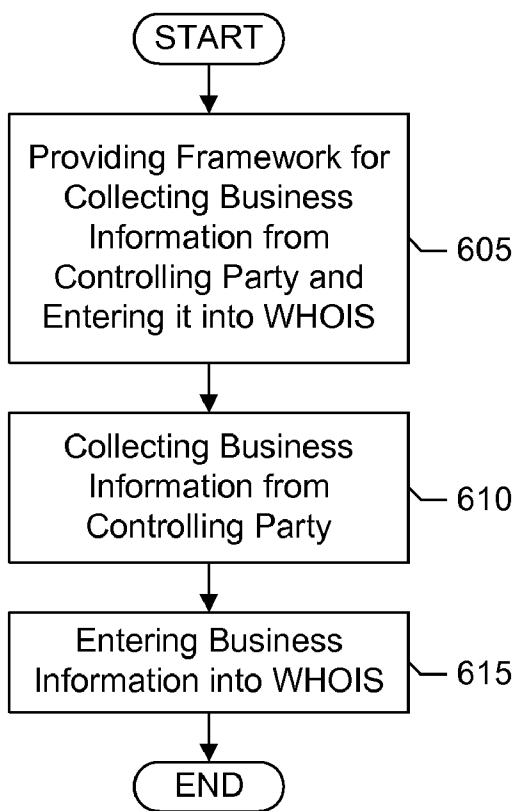

FIG. 6

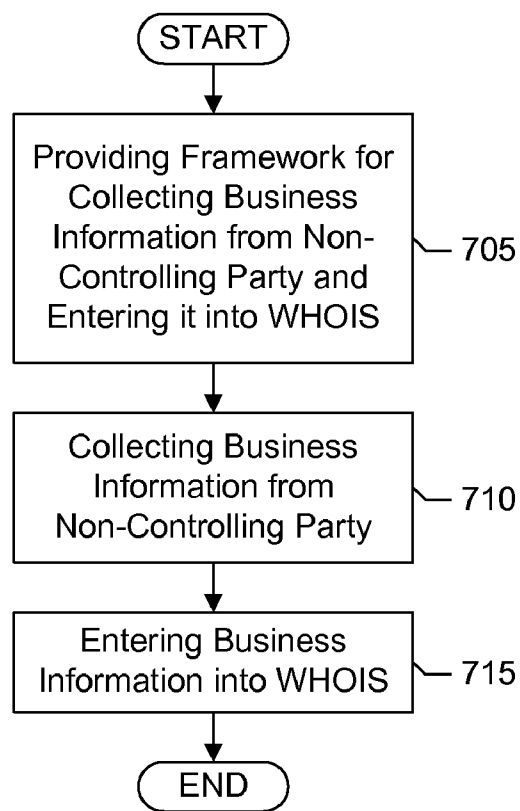

FIG. 7

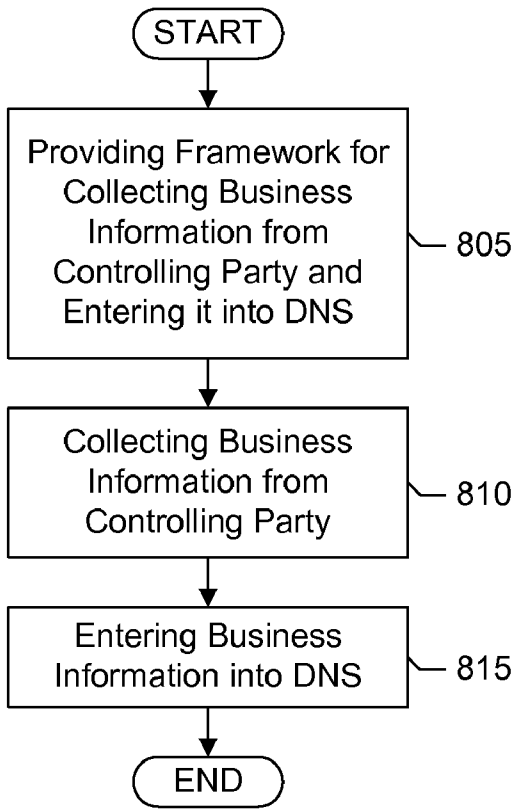

FIG. 8

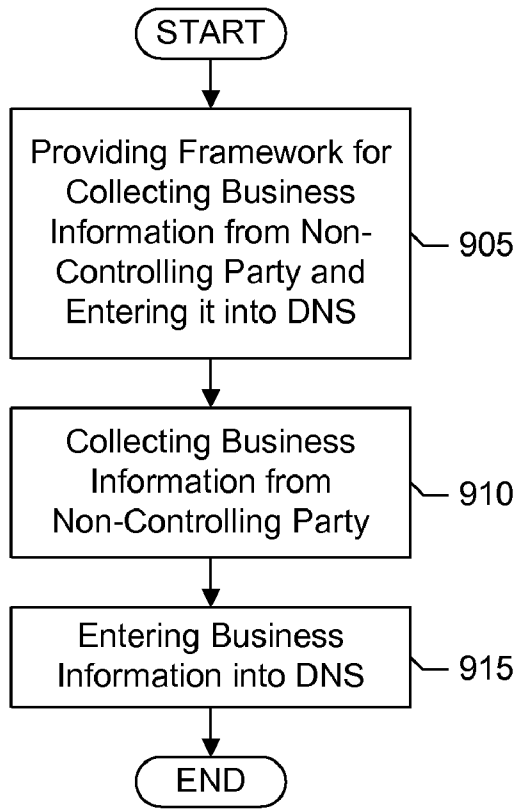

FIG. 9

Registrant:  
GoDaddy.com, Inc.

14455 N Hayden Rd #226  
Scottsdale, Arizona 85260  
United States

Registered through: GoDaddy.com, Inc. (<http://www.godaddy.com>)  
Domain Name: GODADDY.COM  
Created on: 02-Mar-99  
Expires on: 02-Mar-16  
Last Updated on: 24-Jan-07

Administrative Contact:  
GoDaddy.com, Inc., GoDaddy.com, Inc. [dns@jomax.net](mailto:dns@jomax.net)  
GoDaddy.com, Inc.  
14455 N Hayden Rd #226  
Scottsdale, Arizona 85260  
United States  
4805058800 Fax -- 4805058844

Technical Contact:  
GoDaddy.com, Inc., GoDaddy.com, Inc. [dns@jomax.net](mailto:dns@jomax.net)  
GoDaddy.com, Inc.  
14455 N Hayden Rd #226  
Scottsdale, Arizona 85260  
United States  
4805058800 Fax -- 4805058844

Domain servers in listed order:  
CNS1.SECURESERVER.NET  
CNS2.SECURESERVER.NET  
CNS3.SECURESERVER.NET

Registry Status: clientDeleteProhibited  
Registry Status: clientRenewProhibited  
Registry Status: clientTransferProhibited  
Registry Status: clientUpdateProhibited

1005 — Comments:  
1: How much is this domain name?  
2: This domain name is not for sale.

1010 — Products for sale:  
1: Domain Names - <https://www.godaddy.com/gdshop/registrar/search.asp>  
2: Hosting - <https://www.godaddy.com/gdshop/hosting/landing.asp>

FIG. 10

```
$TTL 86400

@      IN      SOA      ns1.sample-dns-server.com. info.example.com. (
                          2008021501 ; YYYYMMDDnn, where 'nn' is the revision
                          10800      ; Refresh
                          3600       ; Retry
                          604800     ; Expire
                          3600)      ; Minimum

example.com.             IN NS      ns1.sample-dns-server.com.
example.com.             IN NS      ns2.sample-dns-server.com.
ns1.sample-dns-server.com. IN A      68.178.12.176
ns2.sample-dns-server.com. IN A      68.178.12.121
webmail.example.com.    IN A      68.178.12.176
mssql.example.com.      IN A      68.178.12.176
sitebuilder.example.com. IN A      68.178.12.176
mail.example.com.       IN A      68.178.12.176
example.com.            IN A      68.178.12.176
ftp.example.com.        IN CNAME  example.com.
www.example.com.        IN CNAME  example.com.
example.com.            IN MX     10 mail.example.com.
1105 / example.com.     IN TXT    This Domain is for sale.
                          Price: $350.
1110 / example.com.     IN TXT    Hours of Operation: Mon-Fri,
                          9 a.m. - 5 p.m.
1115 / example.com.     IN TXT    Third party comment: Who
                          should I contact about the
                          purchase of this domain?
```

FIG. 11



**INTERACTIVE DNS FOR  
NON-CONTROLLING PARTY**

**CROSS REFERENCE TO RELATED PATENT  
APPLICATION**

**[0001]** This patent application is related to U.S. patent application Ser. No. \_\_\_\_\_, "INTERACTIVE WHOIS" concurrently filed herewith and also assigned to The Go Daddy Group, Inc.

**[0002]** This patent application is related to U.S. patent application Ser. No. \_\_\_\_\_, "INTERACTIVE DNS FOR CONTROLLING PARTY" concurrently filed herewith and also assigned to The Go Daddy Group, Inc.

**FIELD OF THE INVENTION**

**[0003]** The present invention relates to new systems and methods for the extension of DNS functionality.

**BACKGROUND OF THE INVENTION**

**[0004]** The Internet comprises a vast number of computers and computer networks that are interconnected through communication links. The interconnected computers exchange information using various services, such as electronic mail and the World Wide Web (WWW). The WWW service allows a server computer system (i.e., web server or website) to send textual and graphical webpages of information to a remote client computer system. The remote client computer system can then display the webpages. Each resource (e.g., computer or webpage) of the WWW is uniquely identifiable by a Uniform Resource Locator (URL). To view a specific webpage, a client computer system specifies the URL for the webpage in a request (e.g., a HyperText Transfer Protocol (HTTP) request). These follow the familiar format http://www.example.com uniquely identifying the particular resource. The request is forwarded to the web server that serves the webpage to the client computer system. When the client computer system receives the webpage, it typically displays the webpage using a browser. A browser is a special-purpose application program that requests and displays the webpages.

**[0005]** WHOIS is a TCP-based (Transmission Control Protocol) transaction-oriented query/response protocol that is used to provide information services to Internet users. While originally used to provide "white pages" services and information about registered domain names, current deployments cover a much broader range of information services. The protocol delivers its content in a human-readable format. A sample WHOIS printout is shown in FIG. 1.

**[0006]** A WHOIS server listens on TCP port 43 for requests from WHOIS clients. The WHOIS client makes a text request to the WHOIS server, then the WHOIS server replies with text content. All requests are terminated with ASCII CR and then ASCII LF. The response might contain more than one line of text, so the presence of ASCII CR or ASCII LF characters does not indicate the end of the response. The WHOIS server closes its connection as soon as the output is finished. The closed TCP connection is the indication to the client that the response has been received.

**[0007]** For historical reasons, WHOIS lacks many of the modern protocol design attributes, for example internationalization and strong security. The WHOIS protocol has no mechanism for indicating the character set in use. Originally, the predominant text encoding in use was US-ASCII. In practice, some WHOIS servers, particularly those outside the

USA, might be using some other character set either for requests, replies, or both. This inability to predict or express text encoding has adversely impacted the interoperability (and, therefore, usefulness) of the WHOIS protocol.

**[0008]** The WHOIS protocol has no provisions for strong security. WHOIS lacks mechanisms for access control, integrity, and confidentiality. Accordingly, WHOIS-based services are used for information which is non-sensitive and intended to be accessible to everyone.

**[0009]** The domain name system (DNS) is the world's largest distributed computing system that enables access to any resource in the Internet by translating user-friendly domain names to IP Addresses. The process of translating domain names to IP Addresses is called Name Resolution. A DNS name resolution is the first step in the majority of Internet transactions. The DNS is in fact a client-server system that provides this name resolution service through a family of servers called Domain Name Servers. The hierarchical domain space is divided into administrative units called zones. A zone usually consists of a domain (say example.com) and possibly one or more sub domains (projects.example.com, services.example.com). The authoritative data needed for performing the name resolution service is contained in a file called the zone file and the DNS servers hosting this file are called the authoritative name servers for that zone. The DNS clients that make use of the services provided by authoritative name servers may be of two types. One type is called a stub resolver that formulates and sends a query every time it receives a request from an application that requires Internet service (e.g., a browser). The other type is called a caching (also called recursive/resolving) name server that caches the name resolution responses it has obtained from the authoritative name servers and is thus able to serve multiple stub resolvers.

**[0010]** The zone file hosted on an authoritative name server consists of various types of records called Resource Records (RRs). A type (RRtype) is associated with each DNS resource record. The code for these RRtypes is assigned by an international organization called Internet Assigned Names Authority (IANA). An RR of a given RRtype in a zone file provides a specific type of information. Some of the common RRtype codes are: NS, MX, CNAME, and A. An NS RR in a zone file gives the fully qualified domain name (FQDN) of the host that is considered the name server for that zone. For example, an NS RR in the zone file of the zone example.com may give the information that the host ns 1.projects.example.com is a name server for the domain projects.example.com. Similarly an MX RR gives the host name for a mail server for the zone. An A RR gives the IP address for a host in a domain within the zone. CNAME provides "canonical name" records and mapping of names in the zone file. A zone file generally consists of multiple RRs of a given RRtype with some exceptions (e.g., there can be only SOA RR in a zone file). It can also have multiple RRs for the same domain name and same (or different) RRtype (e.g., multiple name servers or mail servers for a domain services.example.com). A sample DNS zone file printout is shown in FIG. 2.

**[0011]** The DNS infrastructure consists of many different types of DNS servers, DNS clients, and transactions between these entities. The most important transaction in DNS is the one that provides the core service of DNS (i.e., name resolution service) and is called the DNS Query/Response. A DNS Query/Response transaction is made up of a query originating from a DNS client (generically called a DNS resolver) and

response from a DNS name server. The response consists of one or more RRs. These RRs may be served from its own zone file (for an authoritative name server) or from a cache of RRs obtained from other name servers (for a caching/resolving/recursive name servers). In this way, the DNS serves as a global, distributed database. Name servers (serving zone files) each contain a small portion of the global domain space, and clients issue queries using a domain name and a desired RRtype.

#### BRIEF DESCRIPTION OF THE DRAWINGS

[0012] FIG. 1 is a sample prior art printout of WHOIS data.

[0013] FIG. 2 is a sample prior art printout of DNS zone file data.

[0014] FIG. 3 is a block diagram illustrating a sample embodiment of a system of the present invention using WHOIS.

[0015] FIG. 4 is a block diagram illustrating a sample embodiment of a system of the present invention using DNS.

[0016] FIG. 5 is a block diagram illustrating a sample embodiment of a system of the present invention.

[0017] FIG. 6 is a flowchart showing a sample embodiment of a process for collecting Business Information from Controlling Party and entering it into WHOIS.

[0018] FIG. 7 is a flowchart showing a sample embodiment of a process for collecting Business Information from Non-Controlling Party and entering it into WHOIS.

[0019] FIG. 8 is a flowchart showing a sample embodiment of a process for collecting Business Information from Controlling Party and entering it into DNS.

[0020] FIG. 9 is a flowchart showing a sample embodiment of a process for collecting Business Information from Non-Controlling Party and entering it into DNS.

[0021] FIG. 10 is a sample printout of WHOIS data with Business Information.

[0022] FIG. 11 is a sample printout of DNS zone file data with Business Information.

#### DETAILED DESCRIPTION

[0023] Referring to FIG. 3, a Controlling Party 305 and a Non-Controlling Party 320 may have a read-only or read-and-write access to the WHOIS records 315 for reading or entering a WHOIS Business Information. The Controlling Party 305 is an individual, an organization, or another entity that has control over a domain name and subsequently the WHOIS records 315 for the domain name. The Controlling Party 305 is typically an owner, a Registrant, an administrator, or a record holder for the domain name, or an entity otherwise responsible for maintaining the domain name. The Non-Controlling Party 320 is an individual, an organization, or another entity that does not have control over the domain name and the WHOIS records 315. The WHOIS records 315 are maintained by a Registering Entity 310, such as a Registry, a Registrar, or a Reseller of a Registry or a Registrar.

[0024] The WHOIS Business Information is information currently not present in the WHOIS records. The WHOIS Business Information does not include information used for technical operation of the domain name, resolution of the domain name through domain servers, registry status of the domain name, reputation information, nor Registrant's, administrative, technical, and/or billing contact information. The WHOIS Business Information may include comments posted by the Controlling Party 305 and the Non-Controlling

Party 320 (see 1005 in FIG. 10), products for sale (see 1010 in FIG. 10), or any other information, discussion, etc. not currently saved in the WHOIS.

[0025] Referring to FIG. 6, the Registering Entity 310 or another entity may provide a framework for collecting the WHOIS Business Information from the Controlling Party 305 and entering it into the WHOIS (step 605). The framework may include a website, a webpage, a web service, a web resource, a software, an API (application programming interface), or another technological solution suitable for collecting the WHOIS Business Information from the Controlling Party 305. The website, webpage, web service, or the web resource may be located at a URL associated with the Controlling Party's domain name, at a URL associated with the Registering Entity 310, at a URL showing WHOIS information for the domain name, at a URL showing DNS information for the domain name, at a URL showing business registration information for the domain name, etc. The webpage may be a static page, a dynamic page, an active page, or a parked page for the domain name. The framework does not include control panels that are used for entering traditional information into the WHOIS. The WHOIS Business Information may be collected from the Controlling Party 305 (step 610) and entered into the WHOIS (step 615). The WHOIS Business Information will be typically available for viewing to everyone along with the traditional WHOIS information.

[0026] Referring to FIG. 7, the Registering Entity 310 or another entity may provide a framework for collecting the WHOIS Business Information from the Non-Controlling Party 320 and entering it into the WHOIS (step 705). The framework may include a website, a webpage, a web service, a web resource, a software, an API (application programming interface), or another technological solution suitable for collecting the WHOIS Business Information from the Non-Controlling Party 320. The website, webpage, web service, or the web resource may be located at a URL associated with the Controlling Party's domain name, at a URL associated with the Registering Entity 310, at a URL showing WHOIS information for the domain name, at a URL showing DNS information for the domain name, at a URL showing business registration information for the domain name, etc. The webpage may be a static page, a dynamic page, an active page, or a parked page for the domain name. The framework does not include control panels that are used for entering traditional information into the WHOIS. The WHOIS Business Information may be collected from the Non-Controlling Party 320 (step 710) and entered into the WHOIS (step 715). The WHOIS Business Information will be typically available for viewing to everyone along with the traditional WHOIS information.

[0027] For example, the Non-Controlling Party 320 may ask "How much is this domain name?" and the Controlling Party 305 may reply "This domain is not for sale." (See 1005 in FIG. 10). The WHOIS Business Information may be saved in the WHOIS as text, as character-separated (delimited) text, as fixed width columns text, as markup language formatted text, or in any other form. The markup language formatted text may include HTML, XML, or any other markup language. The Registering Entity 310 may impose further limitations on which tags can be used in the markup language; e.g. scripts can be prohibited. Additionally a link, an image, a banner, or any other multimedia information may be saved into the WHOIS. Involved parties may also participate in a link exchange and/or a banner exchange.

**[0028]** Referring to FIG. 4, a Controlling Party 305 and a Non-Controlling Party 320 may have a read-only or read-and-write access to the DNS records 415 for reading or entering a DNS Business Information. The Controlling Party 305 is an individual, an organization, or another entity that has control over a domain name and subsequently the DNS records 415 for the domain name. The Controlling Party 305 is typically an owner, a Registrant, an administrator, or a record holder for the domain name or a website associated with the domain name, or an entity otherwise responsible for maintaining the domain name or the website. The Non-Controlling Party 320 is an individual, an organization, or another entity that does not have control over the domain name and the DNS records 415. The DNS records 415 are maintained by a Hosting Entity 410, such as a Registry, a Registrar, a Hosting Company, or a Reseller of a Registry, a Registrar, or a Hosting Company. The Hosting Entity 410 typically hosts a website, a webpage, an email address, a DNS record, or another network related service, resource, or document (or plurality thereof) associated with the domain name.

**[0029]** The DNS Business Information is information currently not present in the DNS records. The DNS Business Information does not include information used for technical operation of the domain name, resolution of the domain name through domain servers, nor reputation information. The DNS Business Information may include information about the business, hours of operation (see 1110 in FIG. 11), maps and directions, products for sale, comments posted by the Controlling Party 305 and the Non-Controlling Party 320 (see 1105 and 1115 in FIG. 11), or any other information, discussion, etc. not currently saved in the DNS.

**[0030]** Referring to FIG. 8, the Hosting Entity 410 or another entity may provide a framework for collecting the DNS Business Information from the Controlling Party 305 and entering it into the DNS (step 805). The framework may include a website, a webpage, a web service, a web resource, a software, an API (application programming interface), or another technological solution suitable for collecting the DNS Business Information from the Controlling Party 305. The website, webpage, web service, or the web resource may be located at a URL associated with the Controlling Party's domain name, at a URL associated with the Hosting Entity 410, at a URL showing WHOIS information for the domain name, at a URL showing DNS information for the domain name, at a URL showing business registration information for the domain name, etc. The webpage may be a static page, a dynamic page, an active page, or a parked page for the domain name. The framework does not include control panels that are used for entering traditional information into the DNS. The DNS Business Information may be collected from the Controlling Party 305 (step 810) and entered into the DNS (step 815). The DNS Business Information will be typically available for viewing to everyone along with the traditional DNS information.

**[0031]** Referring to FIG. 9, the Hosting Entity 410 or another entity may provide a framework for collecting the DNS Business Information from the Non-Controlling Party 320 and entering it into the DNS (step 905). The framework may include a website, a webpage, a web service, a web resource, a software, an API (application programming interface), or another technological solution suitable for collecting the DNS Business Information from the Non-Controlling Party 320. The website, webpage, web service, or the web resource may be located at a URL associated with the Con-

trolling Party's domain name, at a URL associated with the Hosting Entity 410, at a URL showing WHOIS information for the domain name, at a URL showing DNS information for the domain name, at a URL showing business registration information for the domain name, etc. The webpage may be a static page, a dynamic page, an active page, or a parked page for the domain name. The framework does not include control panels that are used for entering traditional information into the DNS. The DNS Business Information may be collected from the Non-Controlling Party 320 (step 910) and entered into the DNS (step 915). The DNS Business Information will be typically available for viewing to everyone along with the traditional DNS information.

**[0032]** For example, the Controlling Party 305 may post a comment "This Domain is for sale. Price: \$350." (See 1105 in FIG. 11). The Non-Controlling Party 320 may ask "Who should I contact about the purchase of this domain?" (See 1115 in FIG. 11). The DNS Business Information may be saved in TXT field in the DNS records or any other field. The DNS Business Information may be saved in the DNS as text, as character-separated (delimited) text, as fixed width columns text, as markup language formatted text, or in any other form. The markup language formatted text may include HTML, XML, or any other markup language. The Hosting Entity 410 may impose further limitations on which tags can be used in the markup language; e.g. scripts can be prohibited. Additionally a link, an image, a banner, or any other multimedia information may be saved into the DNS. Involved parties may also participate in a link exchange and/or a banner exchange.

**[0033]** Additional information on DNS and its records may be found at Mockapetris, RFC1035, Domain Names—Implementation and Specification, November 1987 and Rosenbaum, RFC 1464, Using the Domain Name System To Store Arbitrary String Attributes, May 1993, which are both hereby incorporated in their entirety by reference.

**[0034]** In an alternative embodiment, one or more records posted in WHOIS and DNS may be private, and therefore, available only to the Controlling Party 305 or one or more selected Non-Controlling Parties.

**[0035]** Referring to FIG. 5, access to the WHOIS 315 and the DNS 415 by the Controlling Party 305 and the Non-Controlling Party 320 is performed via a Network 510, such as the Internet. Often technological means used by the Controlling Party 305 and the Non-Controlling Party 320 to access the WHOIS 315 and the DNS 415 don't connect to the Registering Entity 310 and the Hosting Entity 410 directly, but rather use standardized network protocols for access and data exchange.

**[0036]** Further, the elements from the above described systems may be combined in a single system and the steps from the above described methods may be combined in a single method. The methods described above can be performed manually, partially automated, or fully automated.

**[0037]** The above-described embodiments have been provided by way of example, and the present invention is not limited to these examples. Multiple variations and modification to the disclosed embodiments will occur, to the extent not mutually exclusive, to those skilled in the art upon consideration of the foregoing description. Such variations and modifications, however, fall well within the scope of the present invention as set forth in the following claims.

**[0038]** The Abstract accompanying this specification is provided to enable the United States Patent and Trademark

Office and the public generally to determine quickly from a cursory inspection the nature and gist of the technical disclosure and is in no way intended for defining, determining, or limiting the present invention or any of its embodiments.

[0039] The invention claimed is:

- 1. A method, comprising the steps of:
  - a) providing a framework for collecting a DNS Business Information from a Non-Controlling Party of a domain name,
  - b) collecting said DNS Business Information from said Non-Controlling Party, and
  - c) entering said DNS Business Information into a DNS of said domain name.
- 2. The method of claim 1, wherein said framework is a website.
- 3. The method of claim 1, wherein said framework is a webpage.
- 4. The method of claim 1, wherein said framework is a web service.
- 5. The method of claim 1, wherein said framework is located at a URL associated with said domain name.
- 6. The method of claim 1, wherein said framework is a parked page for said domain name.
- 7. The method of claim 1, wherein said steps a), b) and c) are performed by a Registry.
- 8. The method of claim 1, wherein said steps a), b) and c) are performed by a Registrar.
- 9. The method of claim 1, wherein said steps a), b) and c) are performed by a Hosting Provider.
- 10. The method of claim 1, wherein said DNS Business Information, at least in part, is an HTML formatted text.

11. The method of claim 1, wherein said DNS Business Information, at least in part, is an XML formatted text.

12. The method of claim 1, wherein said DNS Business Information is entered into a TXT field of said DNS.

13. A method, comprising the steps of:

- a) providing a framework for collecting a DNS Business Information from a controlling Party of a domain name and a Non-Controlling Party of said domain name,
- b) collecting a First DNS Business Information from said Controlling Party,
- c) entering said First DNS Business Information into a DNS of said domain name,
- d) collecting a Second DNS Business Information from said Non-Controlling Party, and
- e) entering said Second DNS Business Information into said DNS of said domain name.

14. A method, comprising the steps of:

- a) providing a website for collecting a DNS Business Information in an XML format from a Controlling Party of a domain name and a Non-Controlling Party of said domain name,
- b) collecting a First DNS Business Information in said XML format from said Controlling Party,
- c) entering said First DNS Business Information into a DNS of said domain name,
- d) collecting a Second DNS Business Information in said XML format from said Non-Controlling Party, and
- e) entering said Second DNS Business Information into said DNS of said domain name.

\* \* \* \* \*